

Die Vorteile von BPM & SOA vereinigen

Vorschlag für eine Referenzarchitektur
prozess-zentrischer Geschäftsanwendungen



Jan Fetzner

Solution Management Intelligence Platform & NetWeaver
SAP AG

11. Dezember 2009

Agenda



- 1. Introducing BPM & Composite Applications**
2. Business Process Modeling Notation as Lingua Franca for Processes
3. Loose Coupling – a Fundamental SOA Paradigm
4. Business Composition vs. Technical Composition
5. Write Operations out of Uis
6. SAP NetWeaver Composition Environment - Demo
7. Real world example for BPM
8. Summary

Business Process Management: Introduction



“Process” represents the **corporate memory** on how assets are used and work is done

Business process management (BPM) is essentially the practice of managing a company by focusing on

- Defining business processes,
- Describing them in detail,
- Monitoring them with appropriate metrics, and
- Using the improved understanding to optimize the performance of the business.

Unstructured



Documents, Spreadsheets, presentations

eMail IM

Unstructured Collaboration
Most work in companies takes place through informal, unstructured communication using these simple mechanisms

Loosely Structured

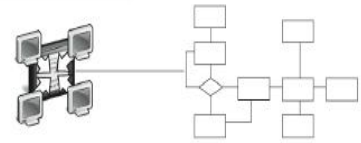

Processes automated and supported through BPM
BPM allows processes to be designed, managed, and automated in a flexible manner

Highly Structured



Enterprise Applications
Enterprise applications automate transactions and structured processes that can be configured

Architecture Maturity Have Change To Business Modularity – A brief history of Architecture maturity



	Business Silos	Standardized Technology	Optimized Core	Business Modularity	Dynamic Venturing
IT capability	Local IT applications	Shared technical platforms	Companywide standardized processes or databases	Plug-and-play business process modules	Seamless merging with partners' systems
Business objectives	ROI of local business initiatives	Reduced IT cost	Cost and quality of business operations	Speed to market; strategic agility	ROI of new business ventures
Who defines applications	Local business leaders	IT and business unit leaders	Senior management and process leaders	IT, business, and industry leaders	IT, business, and industry leaders and partners
Strategic implications	Local/functional optimization	IT efficiency	Business/operational efficiency	Strategic agility	Organic reconfiguration

Source: Ross et. al, 2006

Wikipedia: A Composite Application is an application built by combining multiple existing functions into a new application.

Extended Definition: Composite Applications are **user centric** applications supporting **highly collaborative** and **dynamic business processes** which **span** beyond functional, system, and organizational boundaries by using data and functions **provided as services** by platforms and applications.

Manage Enterprise Business Processes

Step 1: Application Core Processes



1

- Define & Standardize core business processes
- Leverage packaged Business Applications
- Adopt service-enabled industry-specific best practices

Definition

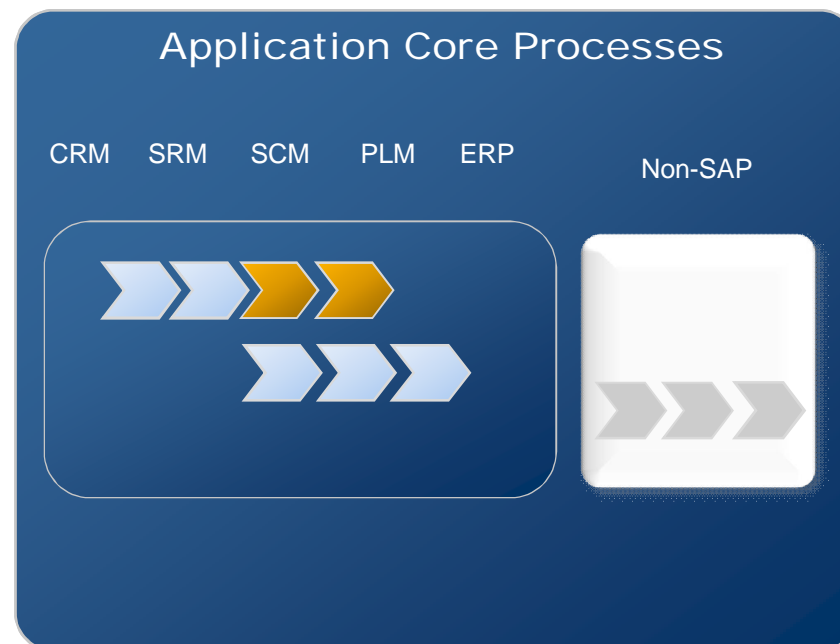

Service Enabled SAP Business Suite



Enabling Faster Flexibility

EXAMPLE

Order to Cash

- Customer Fact Sheet
- Electronic Bill Presentment and Payment
- Credit Management
- Order to Cash
- Bank Relationship Mgmt
- External Cash Desk

Hire to Retire

- Absence Employee Time Request (Duet)
- Benefits & Compensation (Duet)
- Organizational Mgmt (Duet)
- Personnel Admin. (Duet)

Service for Cust.

- Customer Service Execution

Corporate Services

- Asset Configuration
- Maintenance Processing
- Maintenance Service Collaboration
- Travel Management
- Integration of Quality Management Systems
- Batch Traceability & Analytics

Transportation & Warehousing

- Inventory Lookup
- Yard and Storage Mgmt Process

Supplier Relationship

- Supplier Order Collaboration
- External Requirement Processing

Supply Chain

- Service Parts Management
- Demand Planning
- ATP Check
- Supplier Collaboration for the Supply Chain
- Handling of Business Events
- Customer Collaboration for the Supply Chain
- Supply Network and Prod. Planning Processes

Manufacturing / Prod. Development

- Integration of Mfg Execution Systems
- Mfg Work Instructions
- Technical Doc Mgmt Connectivity



View them* in www.sdn.sap.com → Enterprise SOA → Explore Enterprise Services (→ ES Workplace / → ES Wiki)

*Disclaimer: SAP reserves the right to change the ES bundles listed without prior notice. Some of the bundles listed on this page can be viewed in the ES Wiki.

Manage Enterprise Business Processes

Step 2: Composite Business Processes



2

- Compose new innovative business process extensions
- Integrate and extend core business processes

Definition

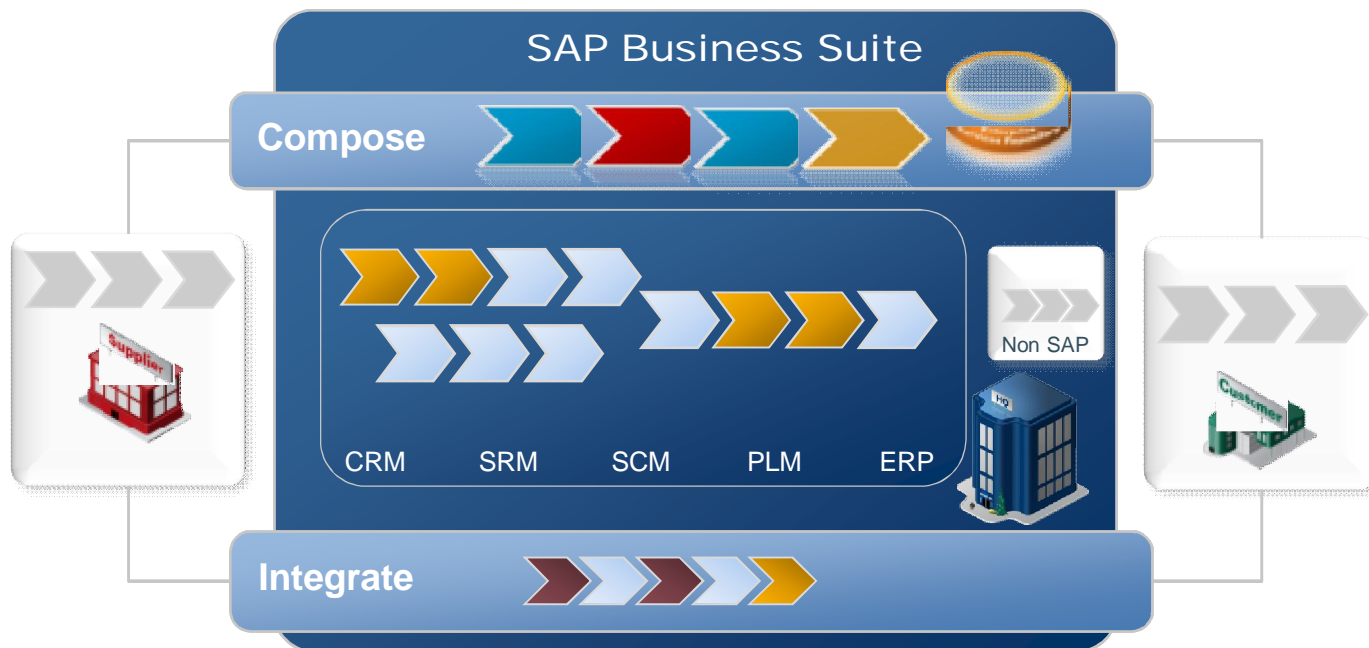

Anatomy of Composite Applications High Level

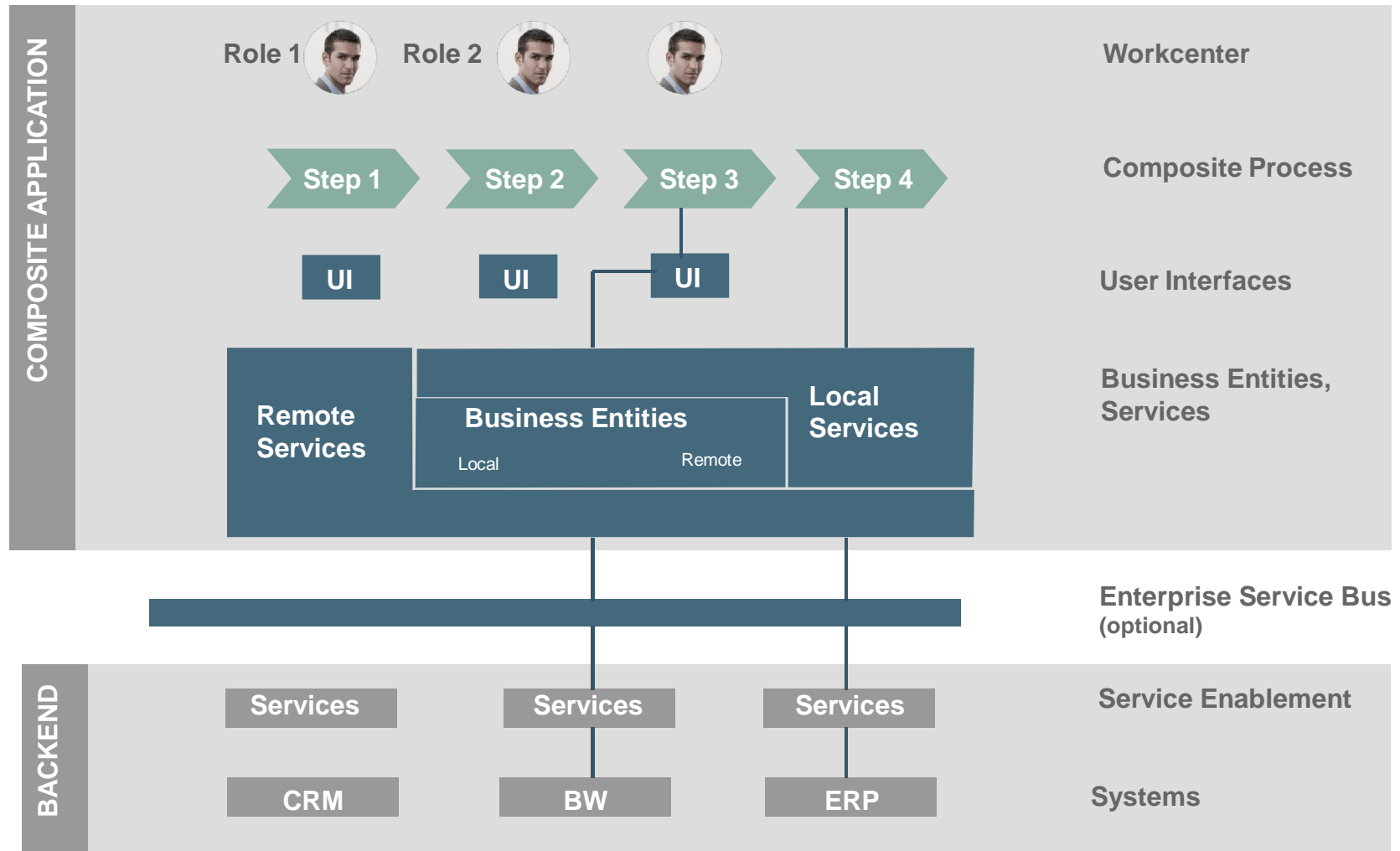

Agenda



1. Introducing BPM & Composite Applications
- 2. Business Process Modeling Notation as Lingua Franca for Processes**
3. Loose Coupling – a Fundamental SOA Paradigm
4. Business Composition vs. Technical Composition
5. Write Operations out of Uis
6. SAP NetWeaver Composition Environment - Demo
7. Real world example for BPM
8. Summary

Composition in Action

Example: Customer Service

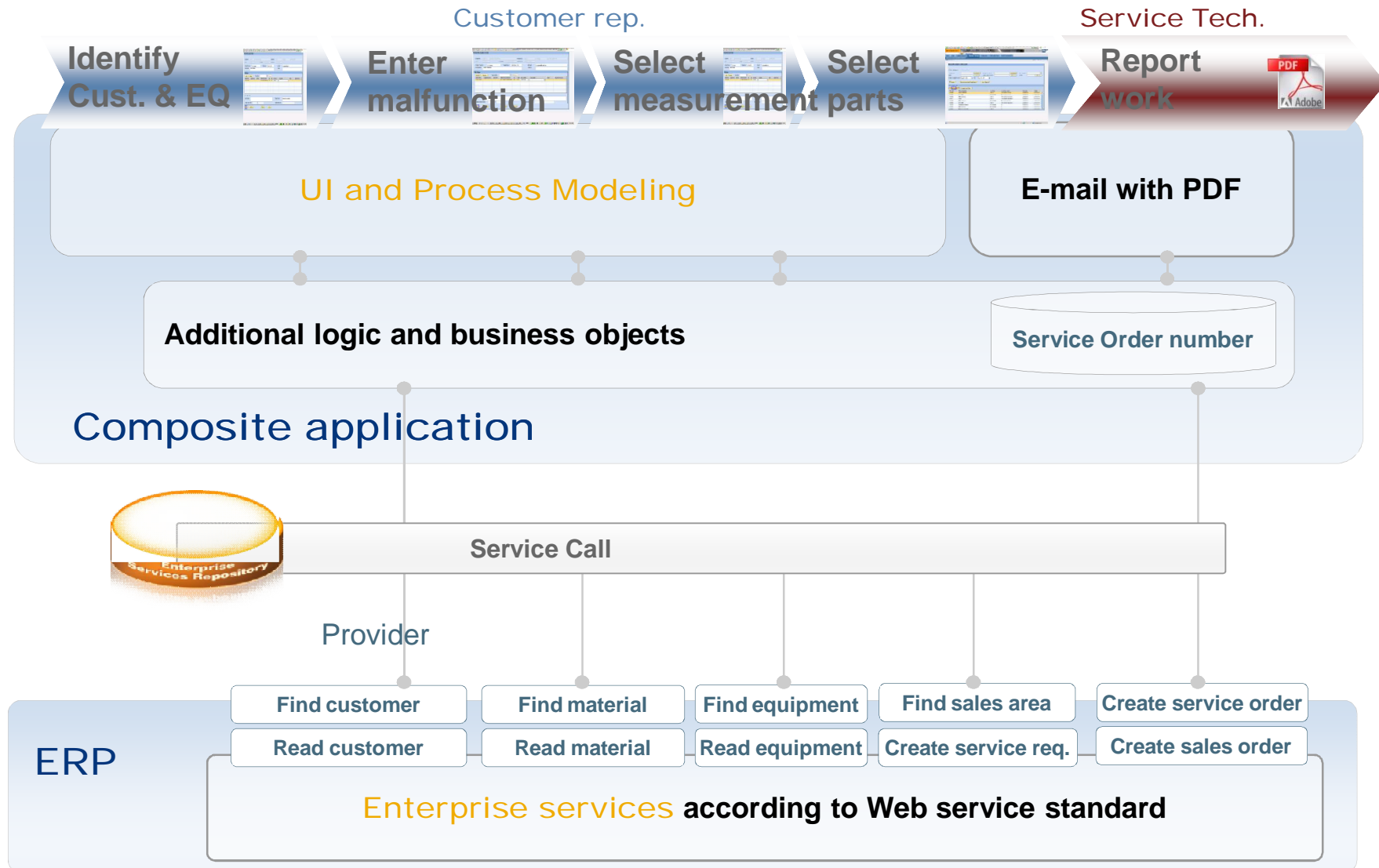

Building Process-centric Applications: End-to-End Experience

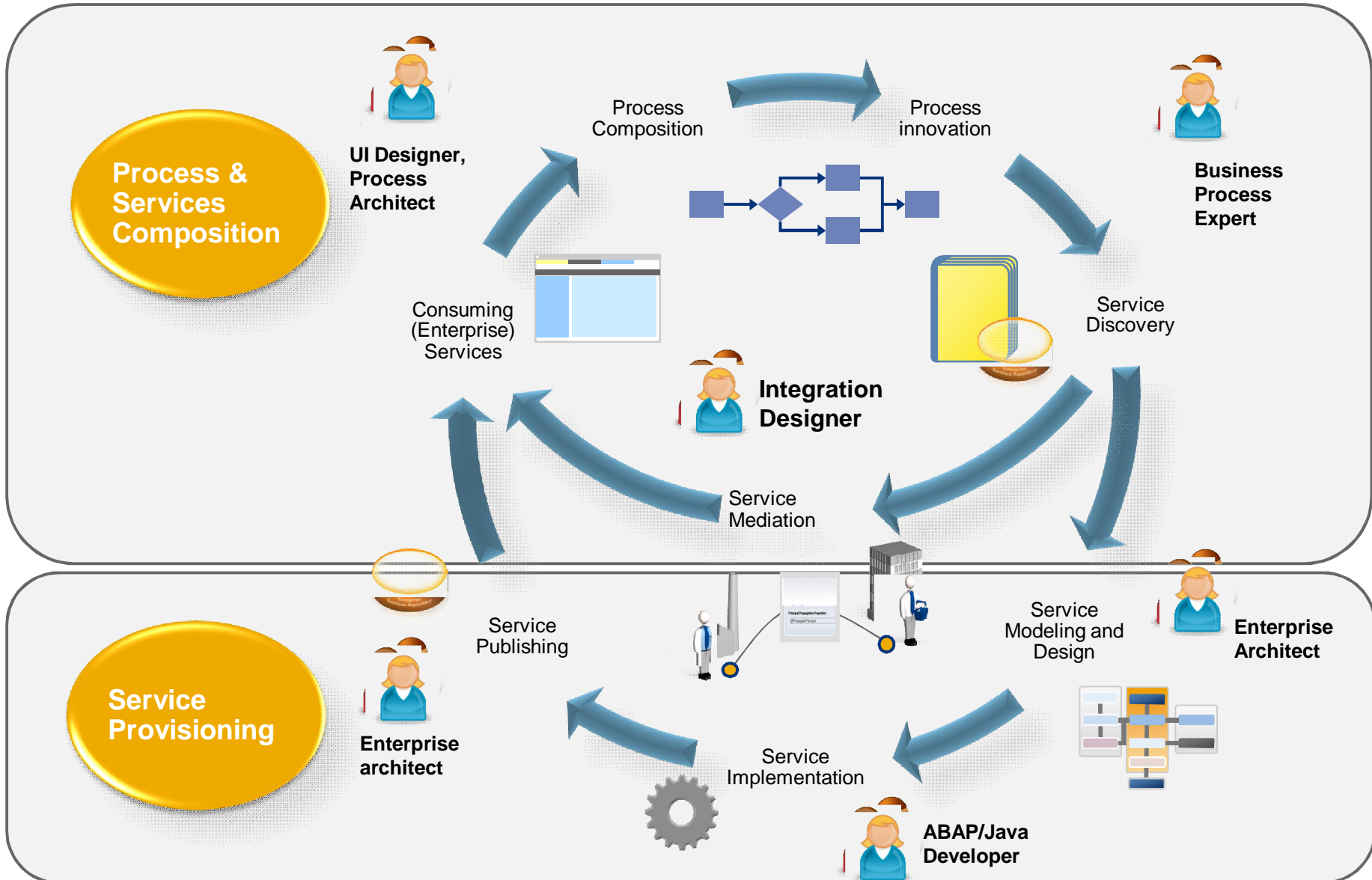



*“The primary goal of BPMN is to provide a notation that is readily understandable by all business users, from the **business analysts** that create the initial drafts of the processes, to the **technical developers** responsible for implementing the technology that will perform those processes, and finally, to the **business people** who will manage and monitor those processes. Thus, BPMN creates a standardized bridge for the gap between the business process design and process implementation.”*

OMG, BPMN 1.1 Specification

- Erstveröffentlichung: 2002
- Offizieller Standard der Object Management Group (OMG) seit 2006
- Aktuelle Version: BPMN 1.2

BPMN – Categories of Elements

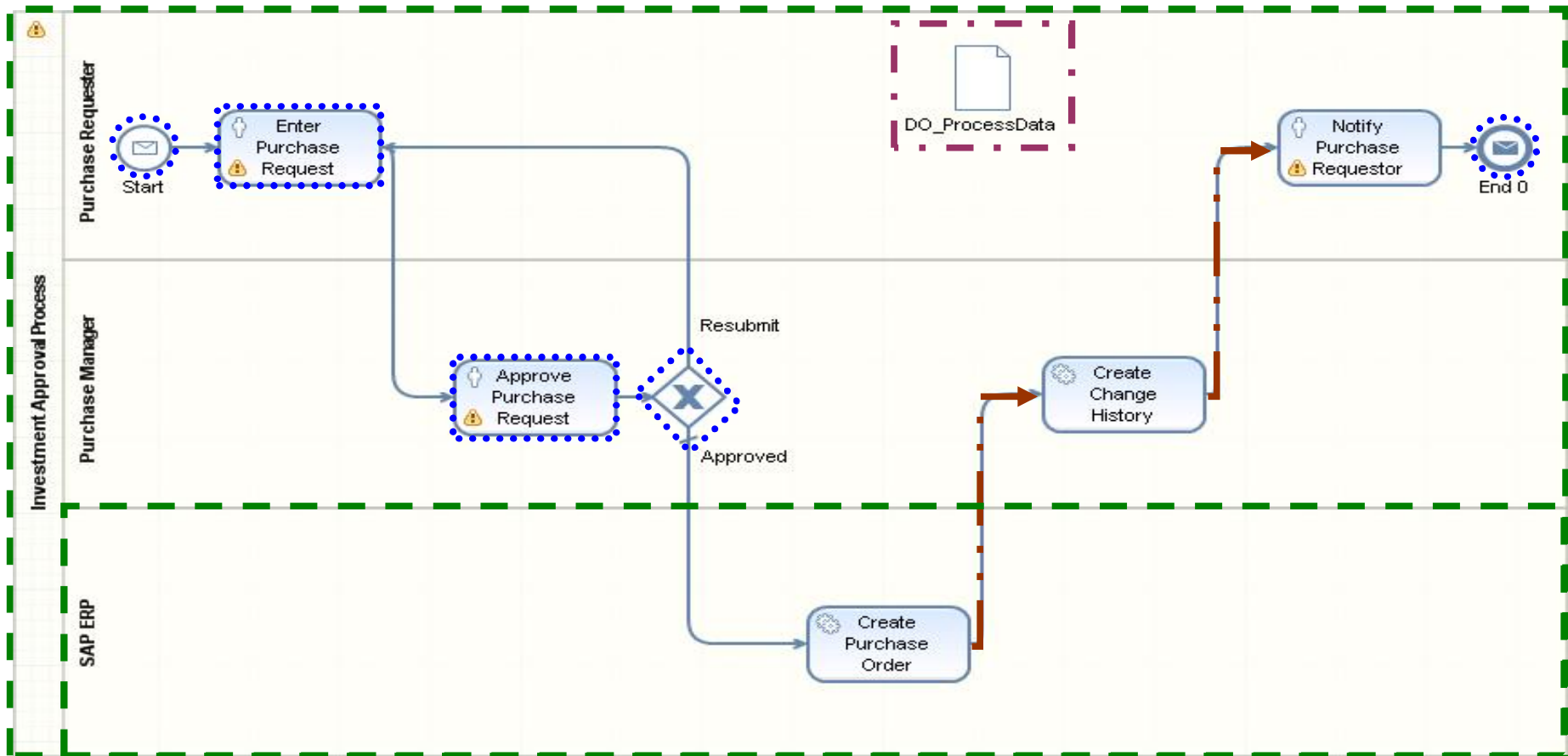

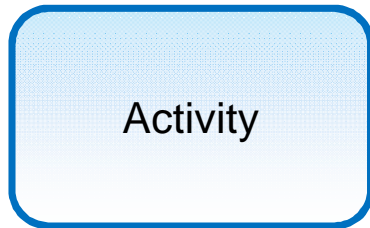

Aktivität (Activity):

- Ein Schritt innerhalb eines Prozesses
- Steht für eine auszuführende Aktion

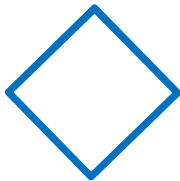

Gateway

Verzweigungen und Zusammenführungen (Gateway):

- Kontrolliert die Aufteilung und Zusammenführung des Kontrollflusses
- Reine Verzweigungslogik – trifft nicht die Entscheidung selbst

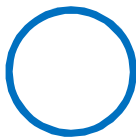

Event

Ereignis (Event):

- Ein Signal, dass „irgendetwas“ passiert ist
- Kann einen Prozess oder Aktivität, starten, unterbrechen, neu anstarten oder umleiten



Aktivität mit Personenbeteiligung (Human Activity):

- Aktivität, die von einer Person bearbeitet werden muss

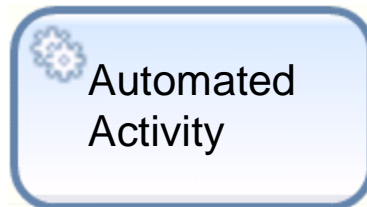

Automatisierte Aktivität (Automated Activity):

- Aktivität, die von einem System übernommen wird

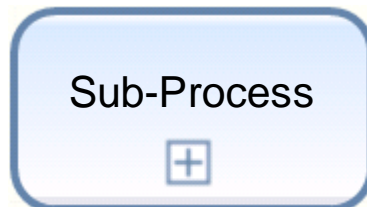

Unterprozess (Sub-Process):

- Eine zusammengesetzte Aktivität, die einen ebenfalls in BPMN modellierten Unterprozess enthält. Darstellbar entweder expandiert oder zusammengeklappt

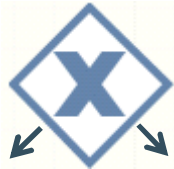

Exklusiver Gateway (Exclusive Choice):

- Lediglich ein Pfad wird ausgewählt
- Jedes Gate wertet einen booleschen **datenbasierten** Ausdruck aus

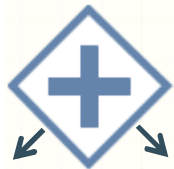

Paralleler Gateway (Parallel Split) (auch: UND Gateway):

- Teilt den Sequenzfluss in parallele Zweige auf



Ereignisbasierte Entscheidung (Event based Choice):

- Auch hier wird lediglich ein Pfad ausgewählt
- Entscheidung basiert auf einem **Ereignis**, nicht auf Daten

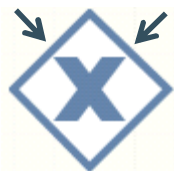

Exklusive Zusammenführung (Uncontrolled Merge):

- Genau ein eingehender Sequenzfluss initiiert die Fortsetzung an einem ausgehenden Sequenzfluss



Parallele Zusammenführung (Parallel Join):

- Alle eingehenden Sequenzflüsse zusammen initiieren die Fortsetzung an einem ausgehenden Sequenzfluss



Start-Ereignis (Start Event):

- Erzeugt eine neue Prozessinstanz oder markiert den Start eines Unterprozesses



Zeitliches Zwischen-Ereignis (Intermediate Timer Event):

- Unterbricht den Sequenzfluss eines Prozesses oder Unterprozesses für eine bestimmte Zeit bzw. bis zu einem bestimmten Zeitpunkt



Nachrichten empfangendes Zwischen-Ereignis (Intermediate Message Event):

- Wartet auf das Eintreffen einer Nachricht



Fehler Zwischen-Ereignis (Intermediate Error):

- Beendet eine Aktivität im Fehlerfall



End-Ereignis (End Event):

- Beendet den Sequenzfluss in einem Prozess/Unterprozess



Terminierung (Termination):

- Beendet den Prozess oder Unterprozess unverzüglich

Business Process Modeling Notation – Orchestrierung und Kollaboration

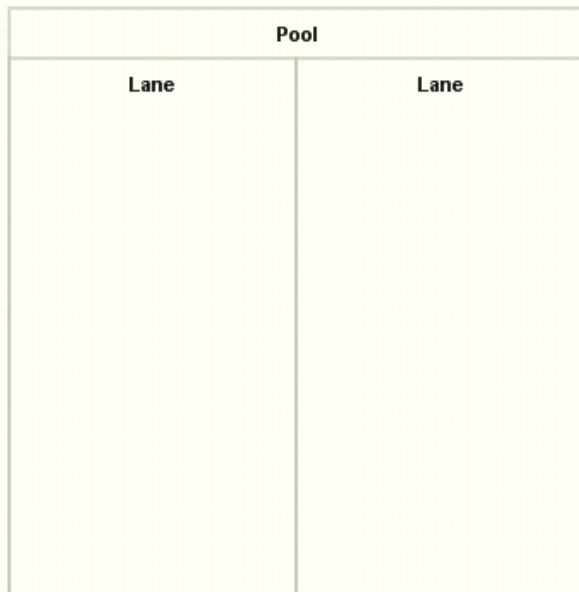

Pool:

- Ein Pool beinhaltet einen einzigen BPMN- Prozess
- Ein Sequenzfluss ist auf genau einen Pool beschränkt
- Ein Prozessdiagramm kann mehrer Pools enthalten
- Unterscheidung zwischen aktiven und inaktive (beschreibenden) Pools

- Lediglich ein aktiver Pool pro Modell

- Ein Pool repräsentiert i.A. eine logische Sammlung von Rollen, Organisationseinheiten und Systemen

(Schwimm-)Bahn (Lane):

- Ein Pool kann in Bahnen unterteilt sein
- Eine Bahn repräsentiert i.A. eine Rolle oder eine Organisations-
einheit



Orchestrierung (Orchestration):

- Legt die Reihenfolge fest, in der die verschiedenen Aktivitäten, Ereignisse und anderen Elemente durchlaufen werden
- Repräsentiert den **Sequenzfluss** (sequence flow)

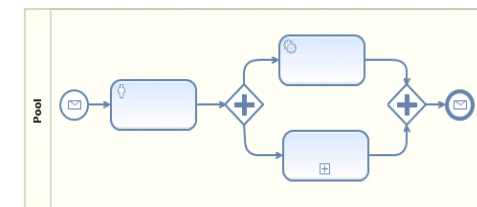

Kollaboration (Collaboration):

- Modelliert die Interaktionen zwischen den Pools
- Repräsentiert den **Nachrichtenfluss** (message flow)

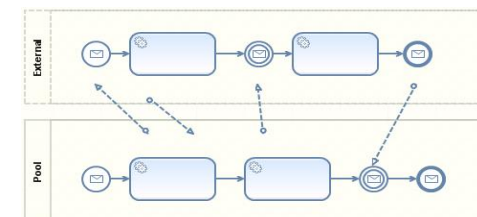

Business Process Modeling Notation (BPMN) – Artefakte



Artefakte:

➤ Neben der Modellierung des Sequenz- und Nachrichtenflusses, erlaubt BPMN die Modellierung sogenannter Artefakte, die ergänzende Informationen beinhalten, wie z.B. Datenobjekte, die die Daten beschreiben, auf denen der Prozess arbeitet oder Anmerkungen, um den Prozess zu erläutern und zu kommentieren.

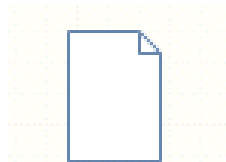

Data Object

Datenobjekt (Data Object):

- Ein Artefakt, das den Prozesskontext beschreibt
- Zugreifbar während der Prozessausführung



Annotation

Anmerkung (Annotation):

- Ermöglicht die Kommentierung des Prozessmodells
- Reine Beschreibung, keine Semantik

BPMN-Diagramm eines Beispielprozesses

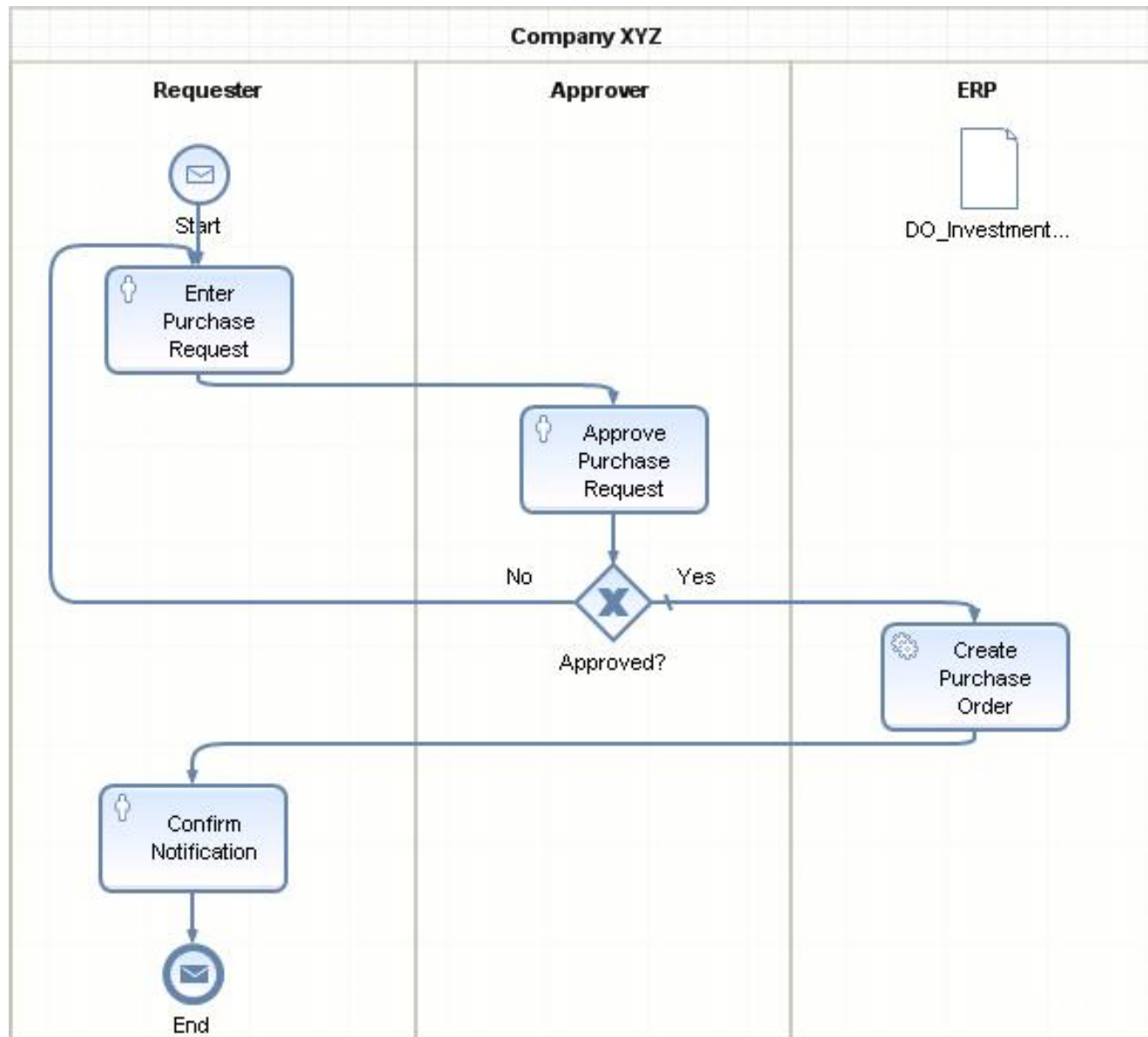

Agenda



1. Introducing BPM & Composite Applications
2. Business Process Modeling Notation as Lingua Franca for Processes
- 3. Loose Coupling – a Fundamental SOA Paradigm**
4. Business Composition vs. Technical Composition
5. Write Operations out of Uis
6. SAP NetWeaver Composition Environment - Demo
7. Real world example for BPM
8. Summary

Typical Customer Requirements (high level)



**It's all about
the interaction between the
composite application
and the
backend systems!**

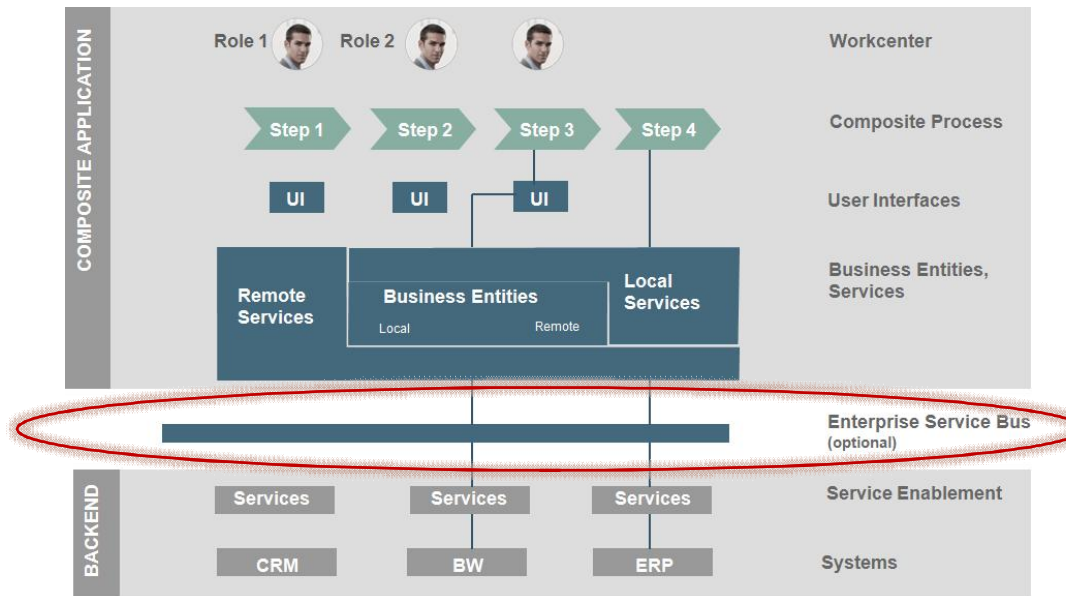

Typical Customer Requirements (high level)



- Make **backend access transparent** to composite applications
 - **Loose coupling** between composite application and backend systems
 - Fast read operations vs. reliable write operations (**synchronous vs. asynchronous**)
 - **Flexibility**: replacing implementations as needed
 - **Standards based** communication method (Web Services)
- **Service contract** between composite application and backend system
 - Driven by **composite's business needs** (top down)
 - Based on a **common canonical data model** (e.g. Global Data Types)
- Exception/error handling: as **close to the backend system** as possible
 - Chances for repairing are higher if errors can be handled close to their root
- Security: **Single Sign-On** between composite application and backend systems which require personalized access
- **Central** governance, configuration, and management for communications
 - Ideal: All communications routed through an Enterprise Service Bus
 - Alternative: information about all communications in one place for impact analysis
 - E.g. SAP NetWeaver PI's advanced adapter engine

What does „loose coupling“ really mean?*



- Loose coupling is a **fundamental SOA concept** in large distributed heterogeneous landscapes
- Different forms of loose coupling exist
 - For a concrete project, decisions have to be made to find the right balance in the spectrum between **tight** and **loose coupling** or **complete independency via data replication**
- Loose coupling **comes at a price** – every form of loose coupling has disadvantages (especially in regard to **complexity**) which have to be considered
- Goal is to **minimize dependencies** between different systems
- **Measuring** “loose coupling”:
 - What are the consequences for system A if you make changes in the called system B?
 - Number of assumptions you make for the connections (e.g. location = physical addresses; receiver = which systems should receive the message; availability of systems; data format; transport protocol = how can you communicate with partners; duration = how long does it take to receive the answer; used technology)
 - Loose coupling = reduce the number of assumptions to a bare minimum

* Compiled from „Enterprise SOA“ by Krafzig/Banke/Slama, „SOA in practice“ by Josuttis and an article by Frotscher published in Java Magazin 6/2009

What Does „Loose Coupling“ Really Mean?*



	Tight Coupling	Loose Coupling
Physical Connection	Point-to-point	Via Mediation
Communication Style	Synchronous	Asynchronous
Data Model	Complex common types	Simple common types
Type System	Strong	Weak
Service Discovery and Binding	Static	Dynamic
Using Platform Specifics	Strong/many	Weak/few
Interaction Pattern	Via complex object trees	Via data-centric, self-contained messages
Transactional Behavior	Two-Phase-Commit	Compensation
Control of Process Logic	Central control	Distributed control
Deployment	At the same time	Different point in time
Versioning	Explicit upgrades	Implicit upgrades

* Taken from „Enterprise SOA“ by Krafzig/Banke/Slama and „SOA in practice“ by Josuttis

Putting it all together

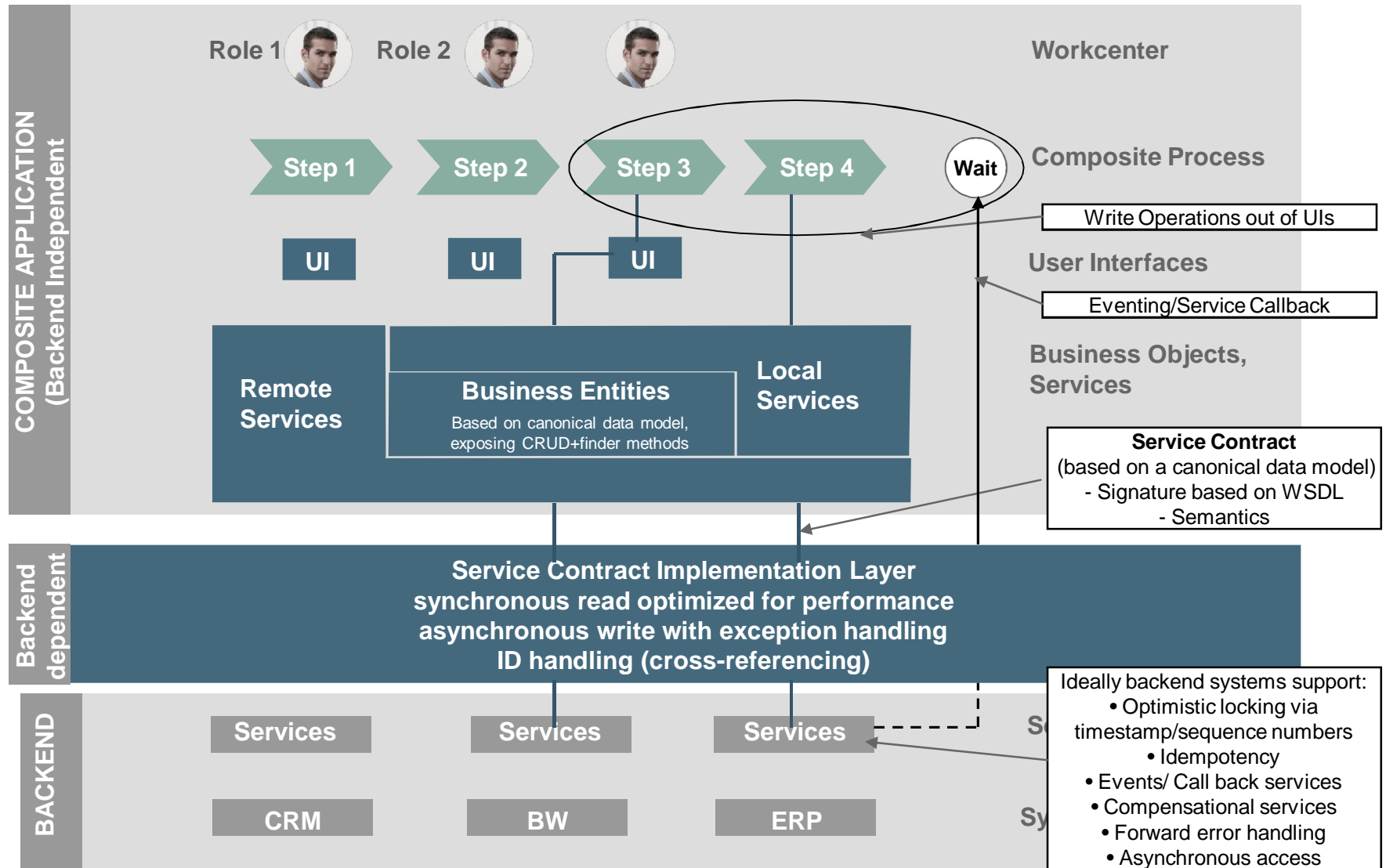

- Ideally backend systems support:
- Optimistic locking via timestamp/sequence numbers
 - Idempotency
 - Events/ Call back services
 - Compensational services
 - Forward error handling
 - Asynchronous access
 - Extensibility concept
 - Bulk operations

Agenda



1. Introducing BPM & Composite Applications
2. Business Process Modeling Notation as Lingua Franca for Processes
3. Loose Coupling – a Fundamental SOA Paradigm
- 4. Business Composition vs. Technical Composition**
5. Write Operations out of Uis
6. SAP NetWeaver Composition Environment - Demo
7. Real world example for BPM
8. Summary

Responsibilities of composite application



■ General structure of the **completely backend independent composite application**

- Process Layer
- User Interface
- Business Entities
 - Locally persisted, application-specific
- Application Services
 - Comprising new business logic
- Works solely on a canonical data model

■ Composite application defines its **external business requirements** via a **service contract**

- WSDL based interface
- Using canonical data model
- Enhanced by business semantics in prose

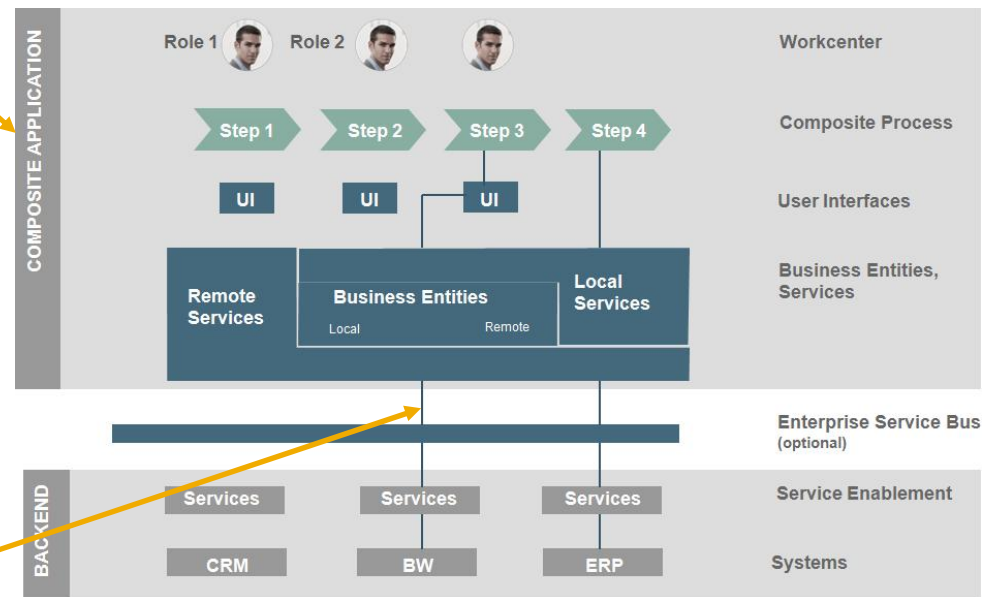

BUSINESS COMPOSITION

Responsibilities of service contract implementation layer



- Separate composite application from backend systems by introducing an additional **backend dependent Service Contract Implementation Layer**
 - Implements the business functionality required by the composite application
 - All kinds of services: connectivity, messaging, routing, security, data transformation (especially to/from canonical data model)
 - Service composition
 - Combining several service calls into higher value services
 - ID cross-referencing for business entities (e.g. reservation)
 - mapping of composite application specific IDs to the ID(s) of the external system(s)
 - Error/Exception handling close to backend systems

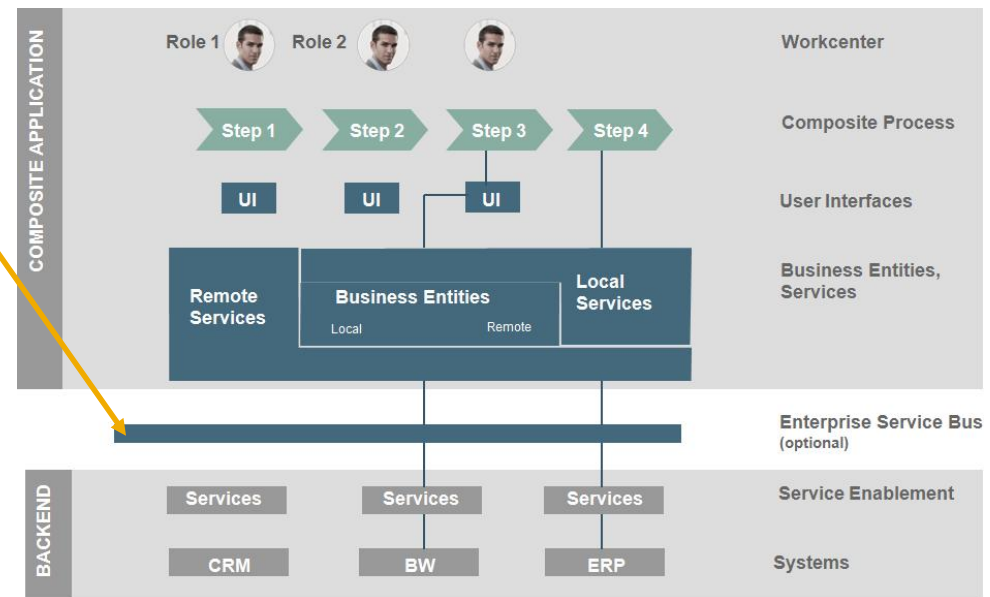

**TECHNICAL
COMPOSITION**

Key Messages Business Composition – Business Analyst View

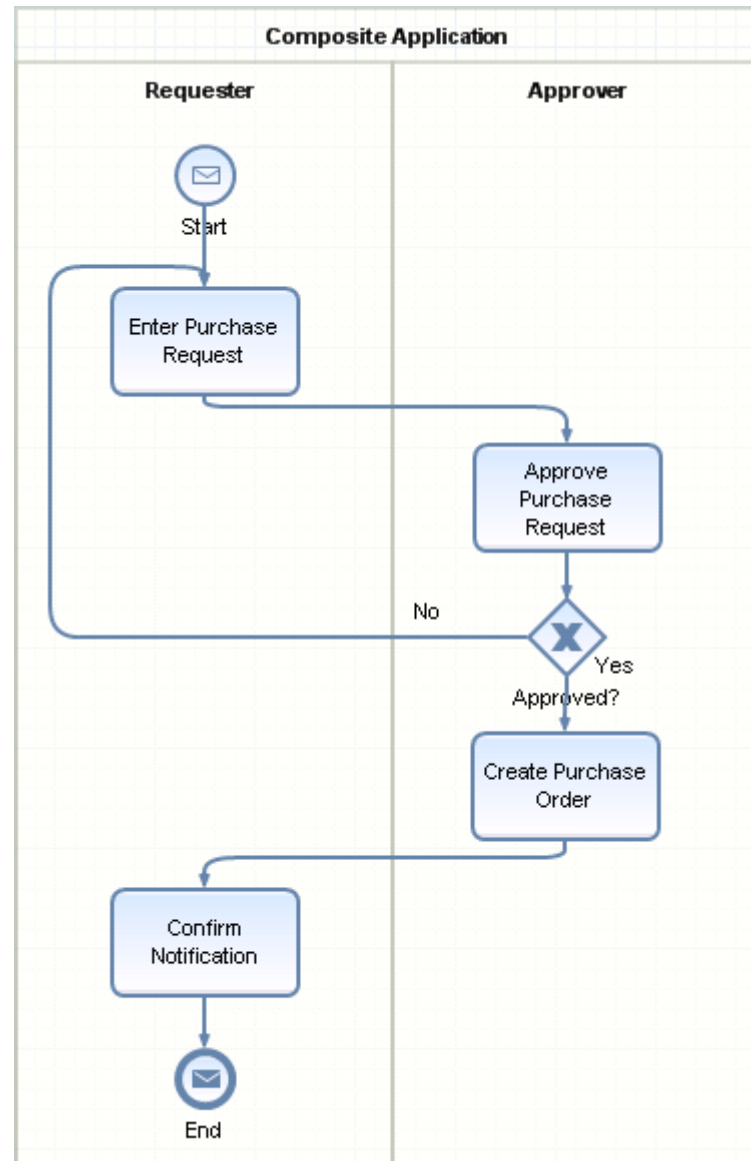

Key Messages Business Composition – Implementation View

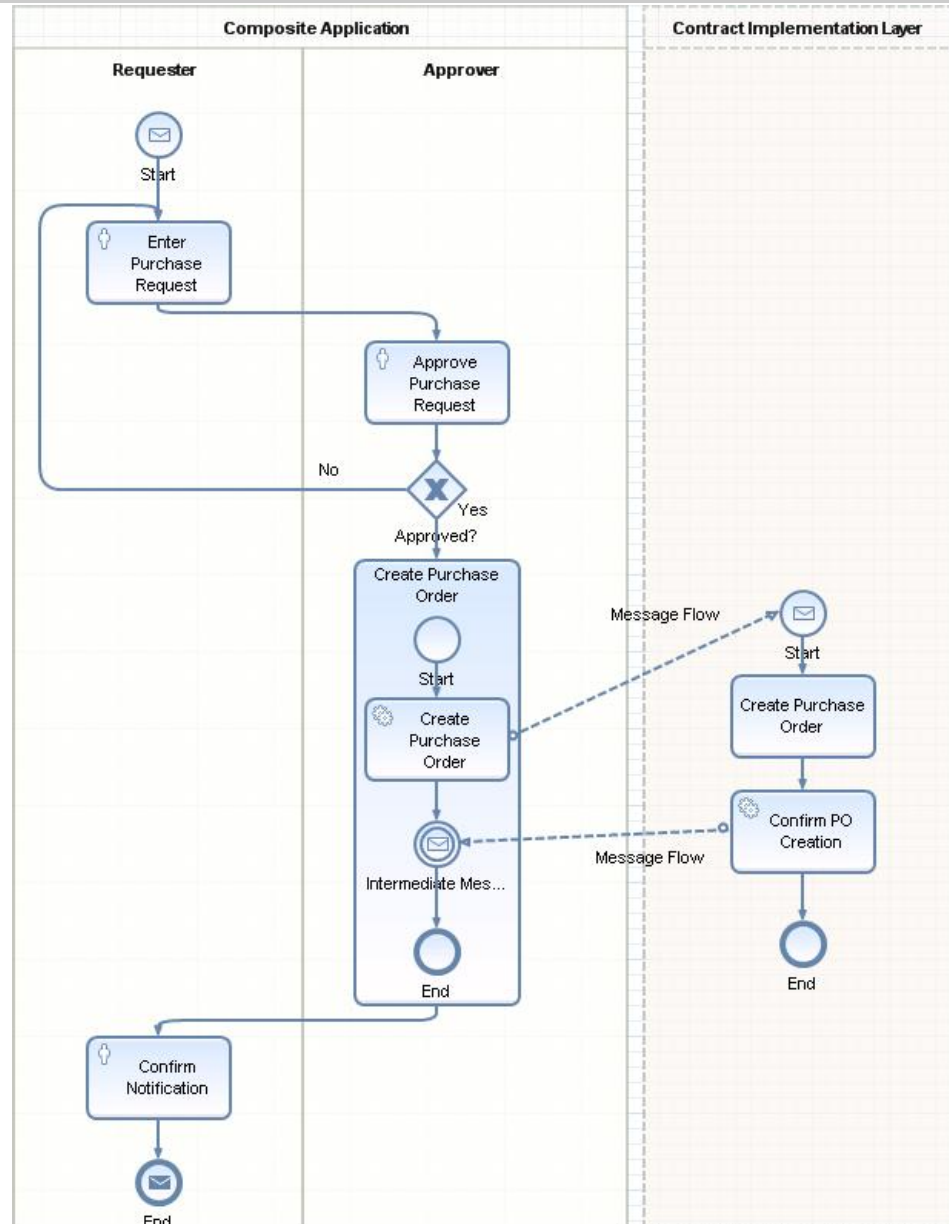

Key Messages

Technical Composition – Implementation View

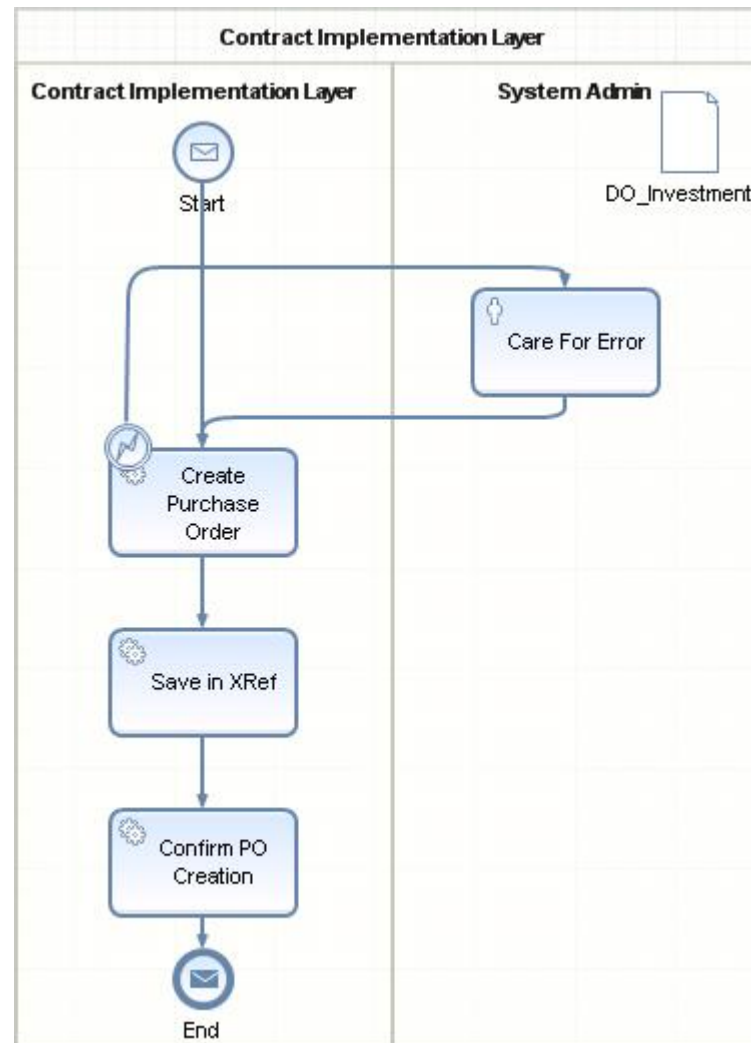

Agenda



1. Introducing BPM & Composite Applications
2. Business Process Modeling Notation as Lingua Franca for Processes
3. Loose Coupling – a Fundamental SOA Paradigm
4. Business Composition vs. Technical Composition
- 5. Write Operations out of Uis**
6. SAP NetWeaver Composition Environment - Demo
7. Real world example for BPM
8. Summary

Write Operations out of UIs in detail

Asynchronous Write Strategy



- Synchronously call service for local persistency
 - Fast
 - End-user immediately gets feedback
 - Internal ID for request generated
- Asynchronously handover request to service contract implementation layer
- Process waits for confirmation from the service contract implementation layer via service callback
- Service contract implementation layer implements functionality as required by the composite
- Service contract implementation layer maintains cross-referencing table
- Callback contains internal ID for correlation purposes
- Process framework provides correlation feature for activating the right instance(s)

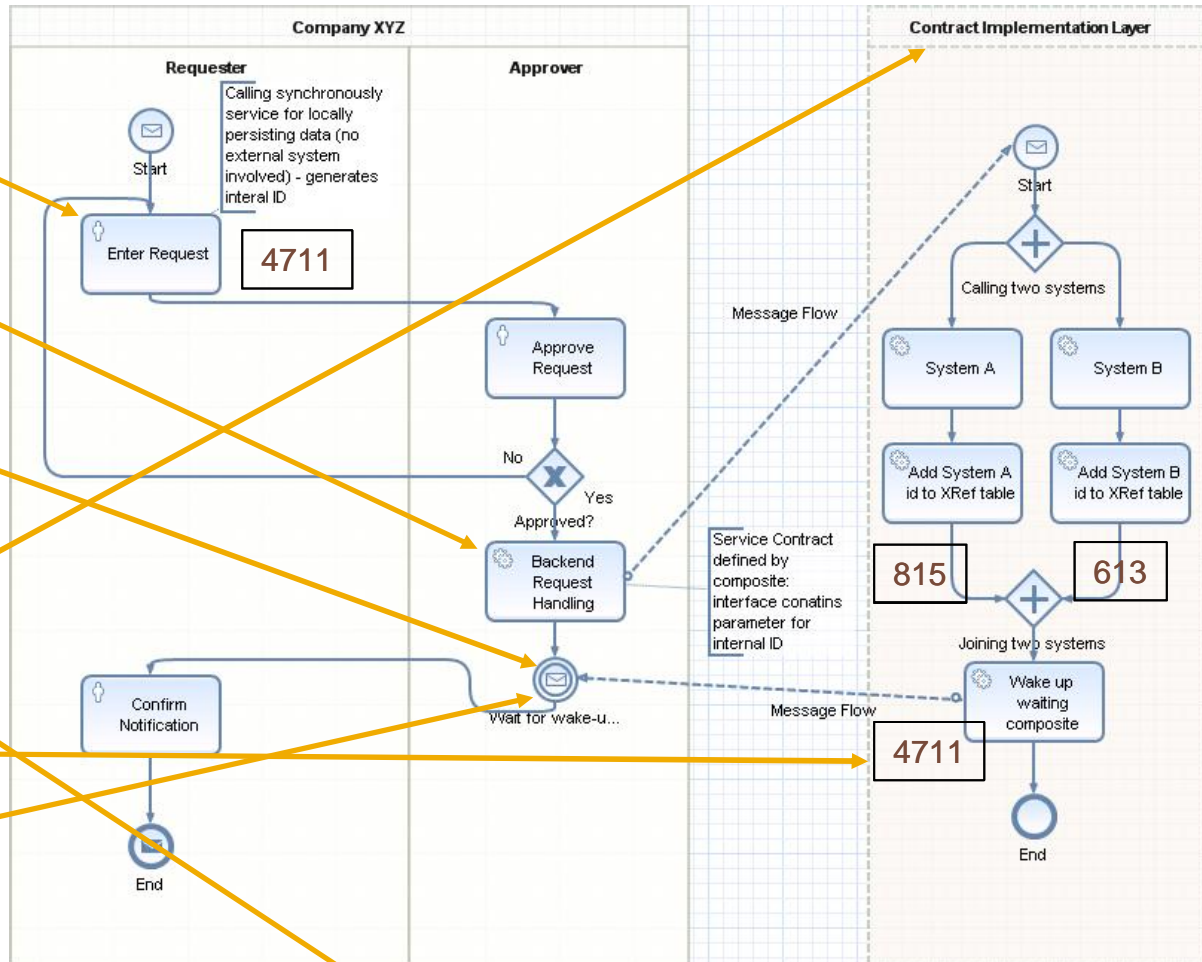

Composite ID	System A ID	System B ID
4711		

Agenda



1. Introducing BPM & Composite Applications
2. Business Process Modeling Notation as Lingua Franca for Processes
3. Loose Coupling – a Fundamental SOA Paradigm
4. Business Composition vs. Technical Composition
5. Write Operations out of Uis
- 6. SAP NetWeaver Composition Environment - Demo**
7. Real world example for BPM
8. Summary

End-to-end SOA Infrastructure – TODAY

Enabling Managed Process Flexibility



User Interface

Portal
 Desktop
 Mobile
 Adobe Forms
 Wiki/Blog
 Pervasive
 Voice
 Search

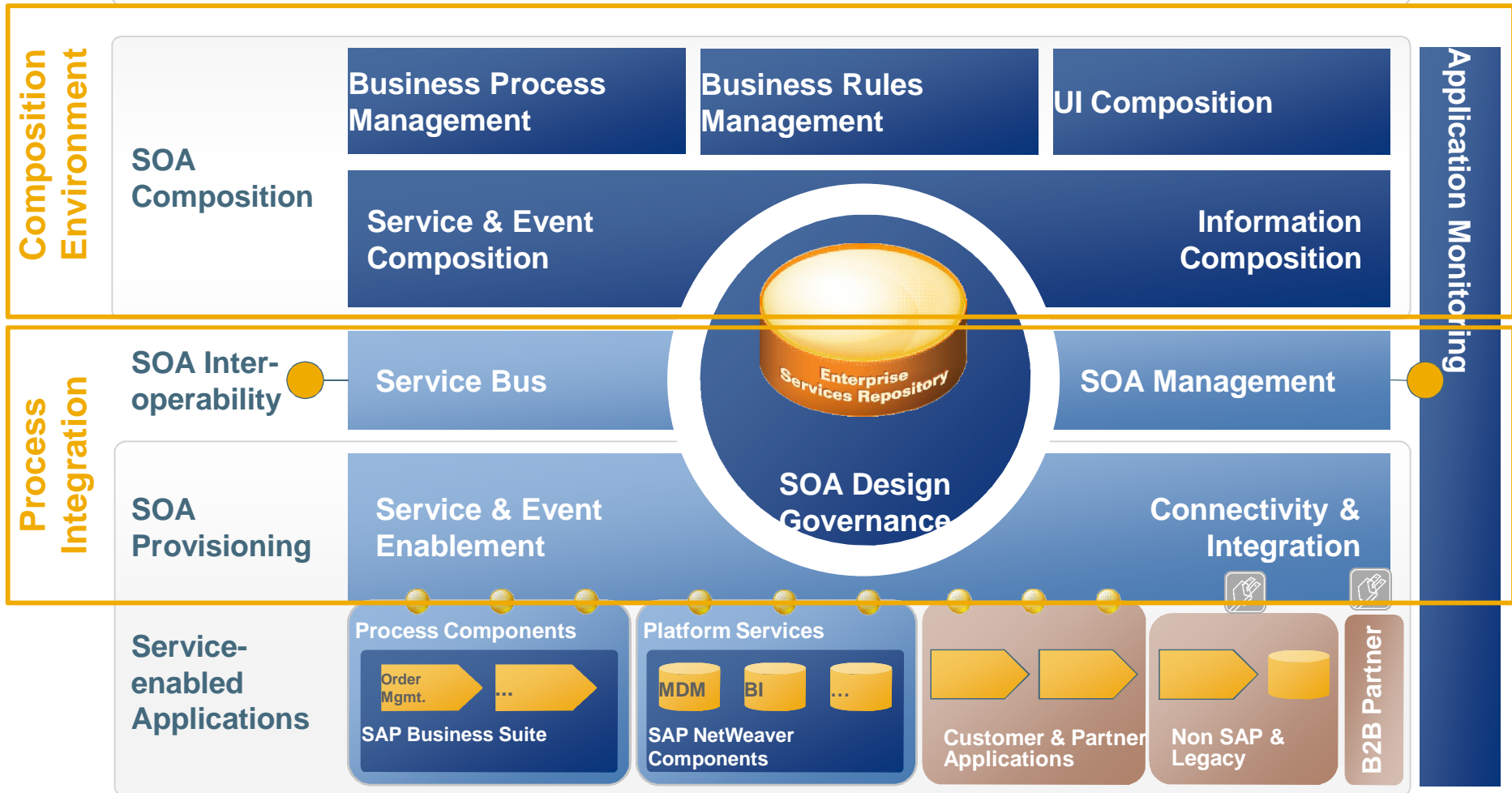

Process Composition Details

SAP NetWeaver Business Process Management in 2009

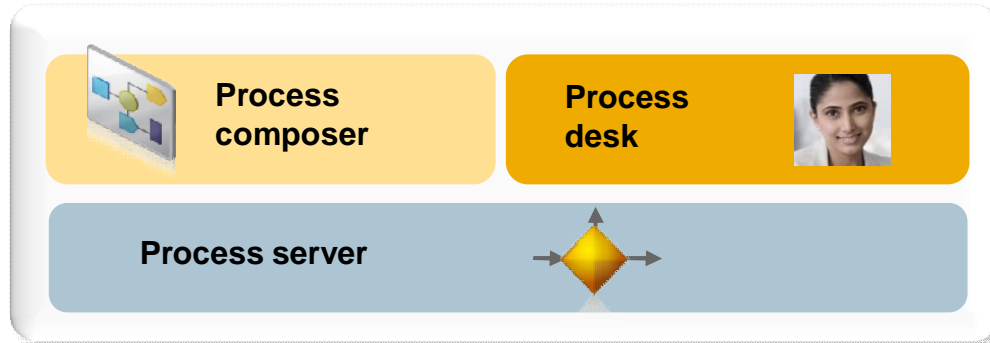

Direct path from business view to process execution

- Model and execute rule-based composite business processes
- Business-friendly graphical modeler based on business process modeling notation (BPMN)
- Combine human interaction and system integration in one model
- Support key process concepts (workflow, event, task, rules, context, roles, and UI) throughout their life cycle
- Process UI generation out of the process context (data types)
- Process reporting with defined reporting points embedded in the process model
- End-to-end eventing integrated with SAP local events (event provisioning) and correlated to the process directly (including intermediate message events)

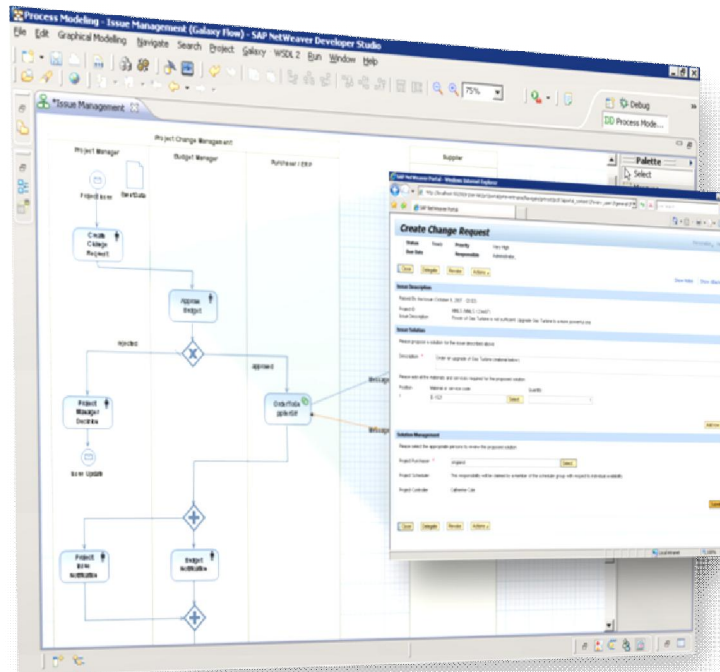

SAP NetWeaver Business Rules Management and SAP NetWeaver Business Process Management



Integration Overview

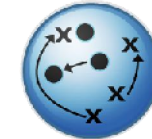
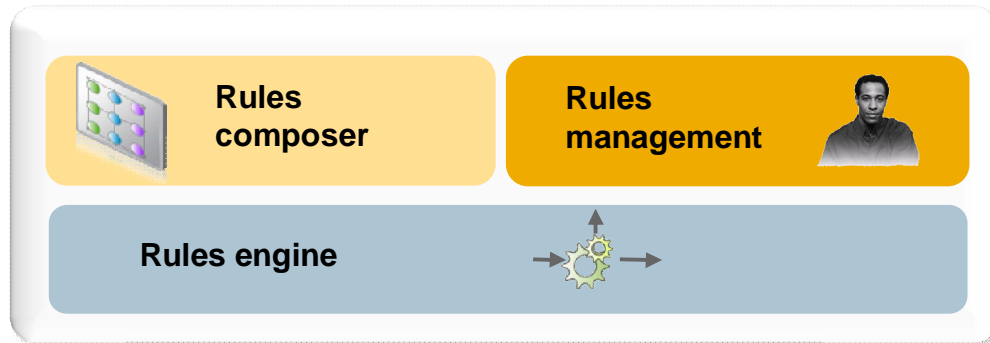

Embedded rules in process to drive process agility

- Robust tool for central business rules management
- Provides a separate graphic modeling tool to model complex rule execution sequences
- Provides a web interface for business users to modify simple if-then rules and decision tables and also manage different versions
- Various ways of modeling rules:
 - Model with rules composer and use as a rules service
 - Model in the context of a business process
- And, many ways to integrate:
 - Rules services through an automated activity
 - Use rules as mapping transforms
 - Use rules through EJB functions
 - Use rules from human-task user interfaces
 - Use rules as gateway conditions

The screenshot shows the SAP NetWeaver Business Rules Management interface. The main window displays a table titled 'Policy Terms Factor Tables'. The table has three columns: 'Product Name', 'Policy Term', and 'Term Factor'. The data is organized into rows for different product types, each with multiple policy terms and their corresponding factors.

Product Name	Policy Term	Term Factor
Conquering Life Plan	2	4.0
	Between 3 and 5	3.9
	Between 6 and 9	3.75
	10	3.6
Maximizing Life Money Back Plan	Between 11 and 15	3.2
	Between 16 and 20	2.9
	2	3.8
	Between 3 and 5	3.45
Life Endowment Plan	Between 6 and 9	3.55
	10	3.4
	Between 11 and 15	3.2
	Between 16 and 20	2.3
Income Secure Plan	2	4.45
	Between 3 and 5	4.15
	Between 6 and 9	3.8
	10	3.7
	Between 11 and 15	3.45
	Between 16 and 20	3.8
	2	3.65
	Between 3 and 5	3.5
	Between 6 and 9	2.37
	10	3.25
	Between 11 and 15	2.9
	Between 16 and 20	2.45



DEMO Loose Coupling in Action



Agenda



1. Introducing BPM & Composite Applications
2. Business Process Modeling Notation as Lingua Franca for Processes
3. Loose Coupling – a Fundamental SOA Paradigm
4. Business Composition vs. Technical Composition
5. Write Operations out of Uis
6. SAP NetWeaver Composition Environment - Demo
- 7. Real world example for BPM**
8. Summary

SAP NetWeaver BPM @ GISA

Leading German IT service provider creates process templates for the utilities industry



IT. Mehr als Standard. **GISA**[®]



“We use SAP NetWeaver BPM to create innovative process templates to meet utility-specific requirements, for example to streamline the process of managing customer inquiries for new electricity connections.”

Hans-Ludwig Reinecke
SAP Manager
GISA GmbH

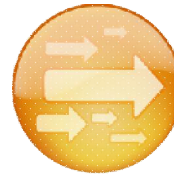

React flexibly to new requirements – De-regulation in the power industry drives the need for utility companies to implement new, flexible processes



Create innovative processes – As a showcase, GISA created a process template that streamlines customer inquiries for new electricity connections via a customer portal



Leveraging a SOA-based development approach – SAP NetWeaver BPM allows GISA to flexibly orchestrate enterprise services and combine them with human interactions in one process model

SAP NetWeaver BPM @ GISA

Leading IT service provider creates process templates for the utilities industry managing customer inquiries for new electricity connections

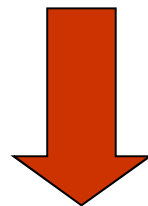
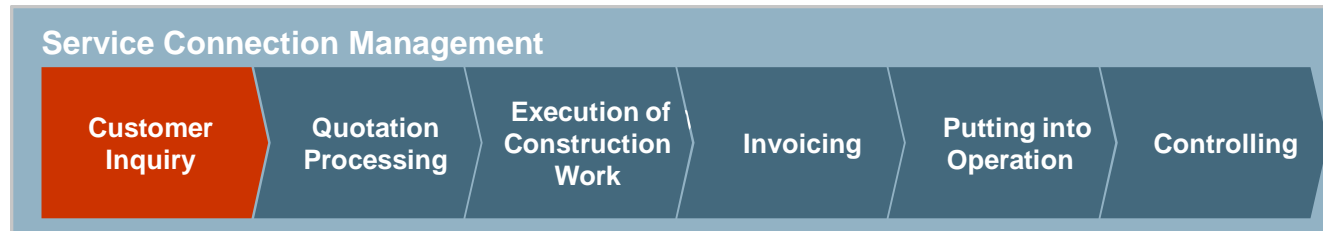

Implemented process template is part of the broader Service Connection Management process



BPMN Model of Implemented Process Template

Process: Manage customer inquiries for new electricity connections



Roles and Systems (Process Lanes)

- Customer
- Customer agent 1
- Customer agent 2
- Customer agent 3
- ERP system

■ Human Activities

- Customer inquiry via web-page (customer)
- Check customer inquiry (customer agent)
- Reject customer request (customer agent)
- Create customer-specific offering (customer agent)
- Create standard-offering (customer agent)

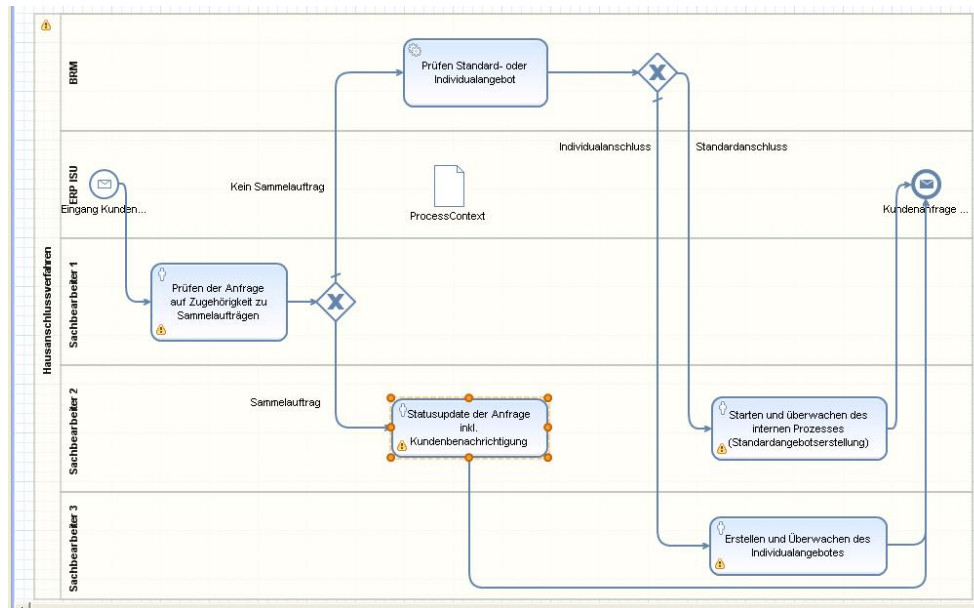

■ Automated Activities (enterprise services)

- Search customer (SAP ERP)
- Get customer details (SAP ERP)
- Create customer record (SAP ERP)
- Search service connection (SAP ERP)
- Check grid capacity (custom development)
- Create customer contact (SAP ERP)
- Create customer inquiry (SAP ERP)
- Check pricing details (custom development)

■ Business Rules

- Automated decision:
Is this a standard or customer-specific offering?



Process Step 1

- Jane requests a new house connection for electrical power via a customer portal

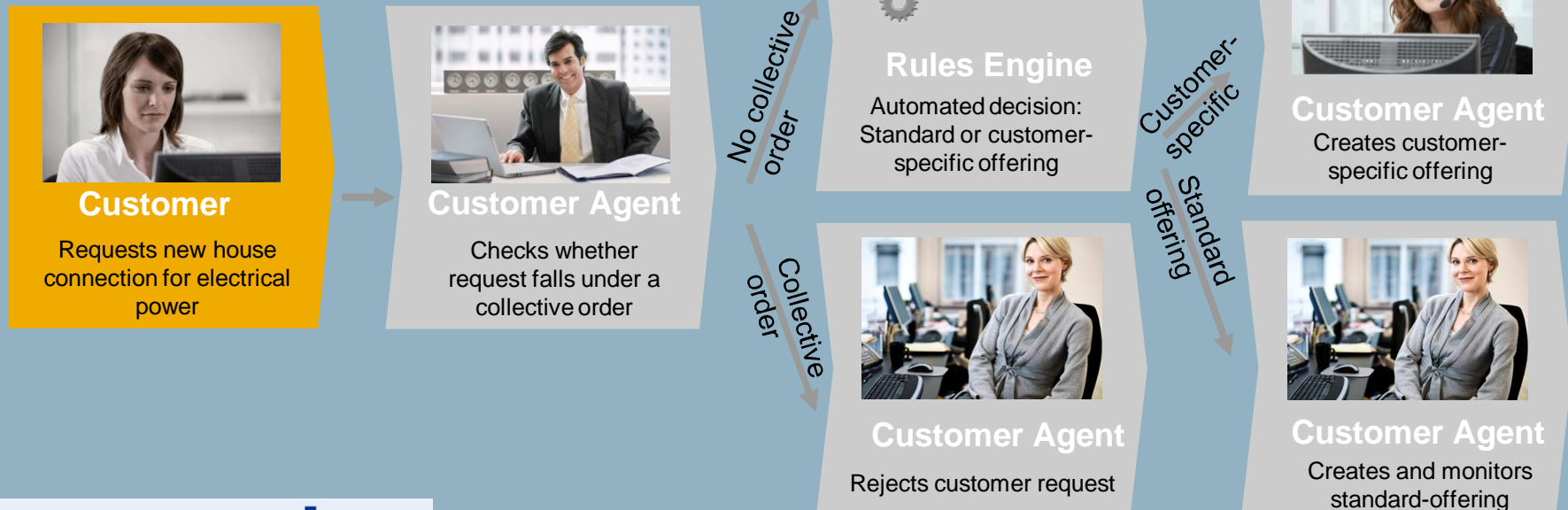

Jane Requests a New House Connection for Electrical Power via a Customer Portal



Request for new electricity connection

Kundendaten

Kundennummer: *wenn vorhanden

Vorname: Nachname:

Straße: Hausnummer:

PLZ: Ort:

Telefon: E-Mail:

Netzanschluss

Straße: Hausnummer:

PLZ: Ort:

Gemarkung/Flur:

Vorhaben: Neuanschluss Anschlussänderung Baustrom

Anschlussart: Haushalt Gewerbe

Zu erwartende Kapazität: 200 V 400 V

Bemerkung:

Fertig 100%



Process Step 2

- Paul checks new request to avoid an overlap with existing collective orders



Paul Sees a New Task in his Universal Worklist to Check New Request to Avoid an Overlap with Existing Collective Orders



The screenshot shows the SAP NetWeaver Portal interface. The browser window title is "Zentraler Arbeitsvorrat - SAP NetWeaver Portal - Windows Internet Explorer". The address bar shows "http://ssap020:53000/irj/portal". The user is logged in as "Anton Albern". The main content area displays the "Universal Worklist" with a task titled "HAV Anfrageprüfung Sammelauftrag". The task details are as follows:

Betreff	Von	Senddatum	Priorität	Fälligkeitsdatum	Status
HAV Anfrageprüfung Sammelauftrag		Heute	Normal		In Bearbeitung

Below the table, the task details are displayed:

HAV Anfrageprüfung Sammelauftrag
Senddatum: Heute Priorität: Normal
Status: In Bearbeitung



Process Step 3a

- Kathleen informs customer about rejection of new house connection request because of an already existing collective order



Kathleen Informs Customer About Rejection of New House Connection Request Because of an Already Existing Collective Order



Hilfe

Gestartet um: 5/18/09 8:42:04 AM **Fällig am** **Status** In Progress **Prozess** [Hausanschlussverfahren](#)
Verantwortlicher Köhler, Michael **Priorität** Medium

Schließen Delegieren Zurücksetzen ▶ Notizen (0) ▶ Anhänge (0)

Reject request (because of existing collective order)

Kundendaten

Kundennummer:
Vorname: Nachname:
Straße: Hausnummer:
PLZ: Ort:
Telefon: E-mail:

Netzanschluss

Straße: Hausnummer:
PLZ: Ort:
Gemarkung/Flur:

Angebotsinformation

Angebotsnr.:
Kunde informiert am

Erledigt

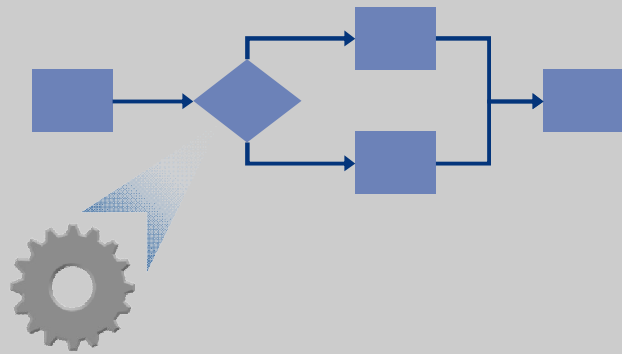

Process Step 3b

- Rules Engine performs automated decision: Standard or customer-specific offering

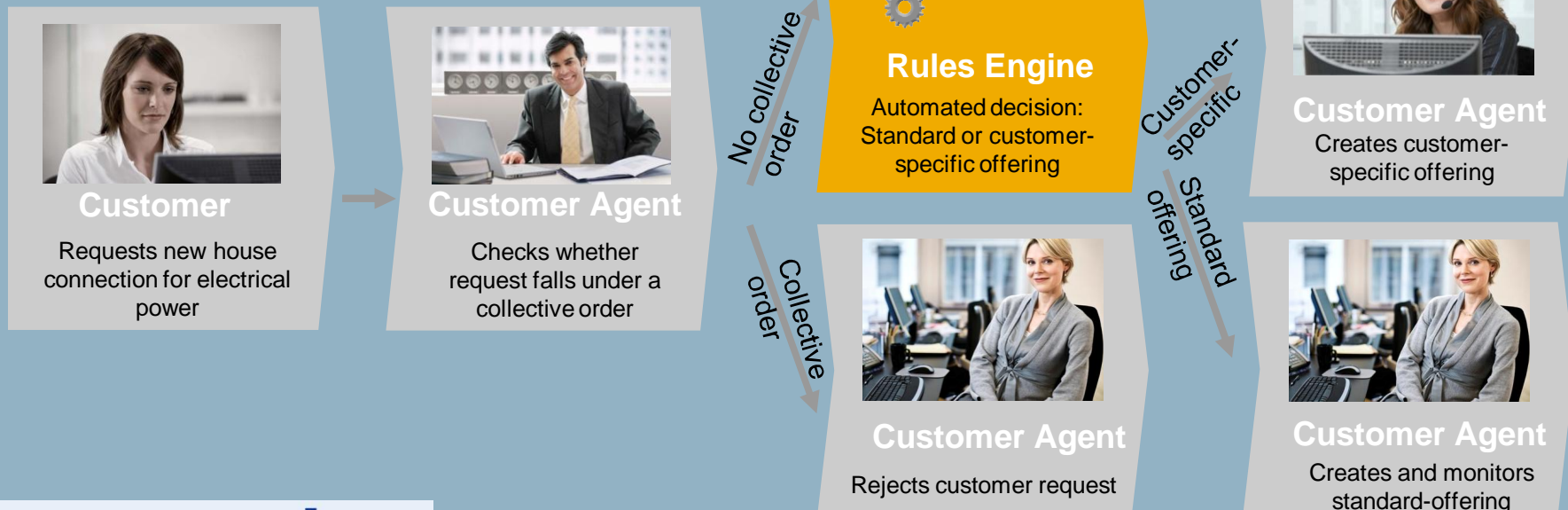

Decision Table to Perform an Automated Decision: Standard or Customer-Specific Offering



► Antragspruefung_Tabelle

Condition... Action... Change Layout Context Menu...

HAVAntragsobjekt.getAntragsart	HAVAntragsobjekt.getAusfuehrungsart	HAVAntragsobjekt.getSparte	HAVAntragsobjekt.setEvaluationvalue ({boolean})
NA	SLP	01	true
		02	false
		04	false
	RLM	01	false
		02	false
		04	false
AA	SLP	01	false
		02	false
		04	false
	RLM	01	false
		02	false
		04	false
BS	SLP	01	false
		02	false
		04	false
	RLM	01	false
		02	false
		04	false



Process Step 4a

- Victoria creates a customer-specific offering

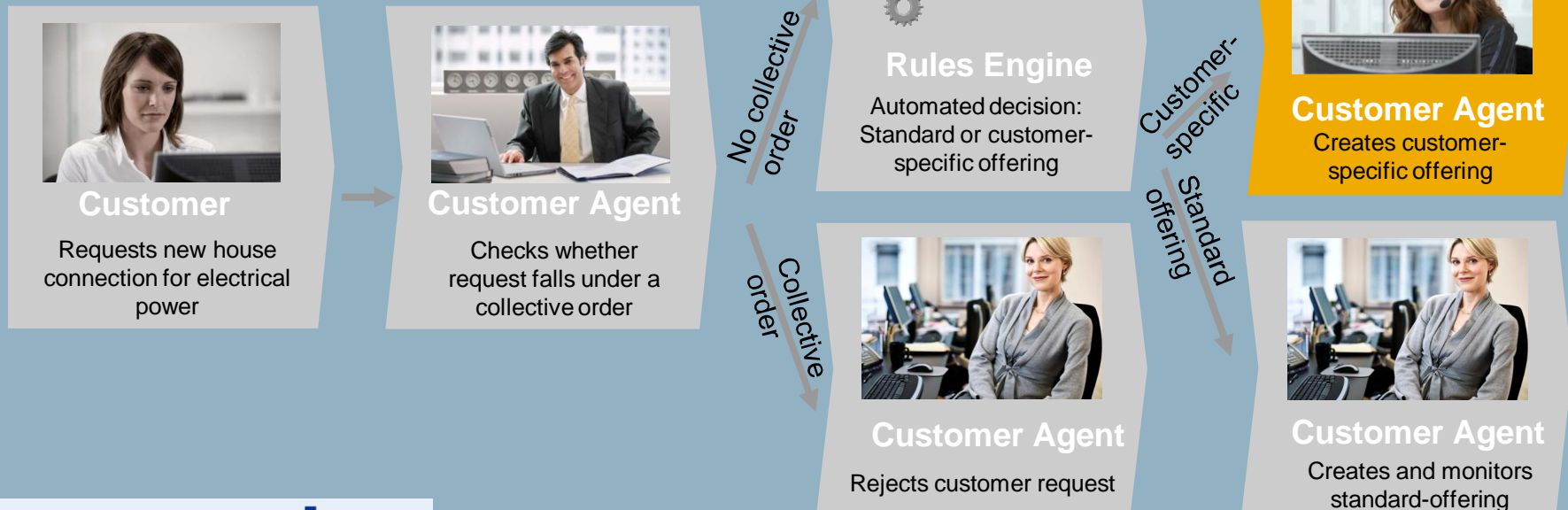

Victoria Creates a Customer-Specific Offering for a New Electricity Connection



Hilfe

Gestartet um: 5/18/09 8:48:38 AM **Fällig am** **Status** In Progress **Prozess** [Hausanschlussverfahren](#)
Verantwortlicher Köhler, Michael **Priorität** Medium

[Schließen](#) [Delegieren](#) [Zurücksetzen](#) [Notizen \(0\)](#) [Anhänge \(0\)](#)

Create customer-specific electricity connection

Kundendaten

Kundennummer:

Vorname: Nachname:

Straße: Hausnummer:

PLZ: Ort:

Telefon: E-mail:

Netzanschluss

Straße: Hausnummer:

PLZ: Ort:

Gemarkung/Flur:

Hausanschluss

Angebotsnr.:

Angebot angepasst und versendet Ja

Projektierung ausgelöst Ja

Auftrag erstellt Ja

Auftrag abgeschlossen Ja

[Wiedervorlage](#) [Erledigt](#)



Process Step 4b

- Kathleen creates a standard-offering

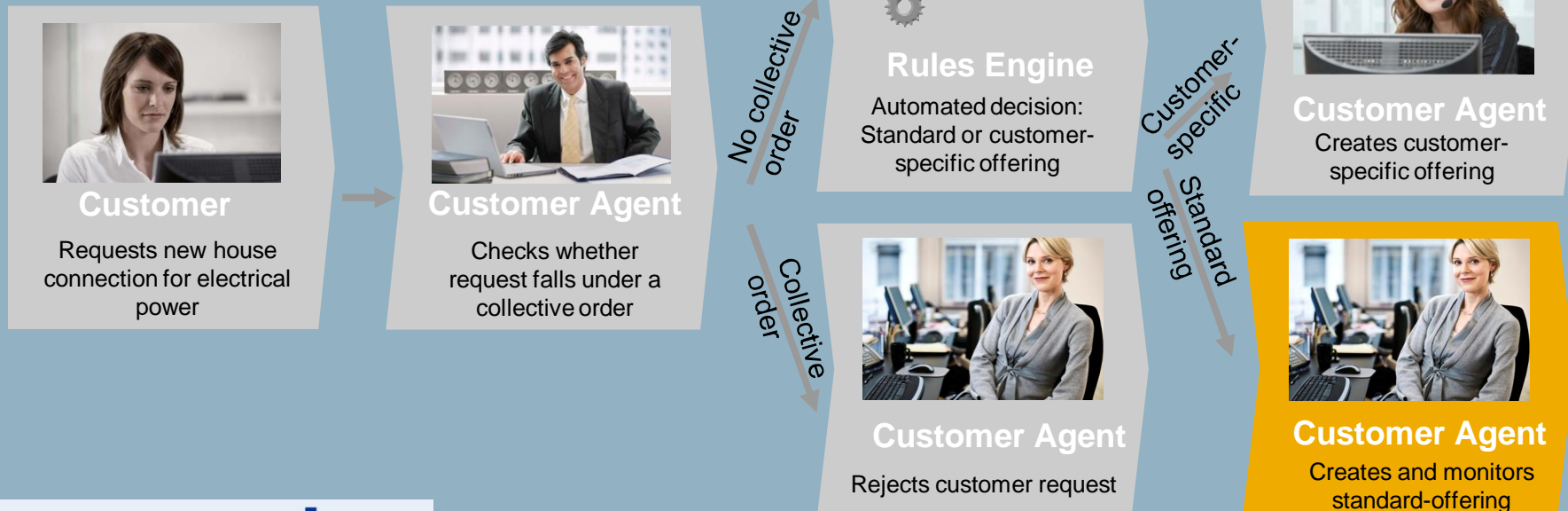

Kathleen Creates a Standard-Offering for a New Electricity Connection



657d122a-97ed-34d1-9759-5593db2500a1 Hilfe

Gestartet um:	5/18/09 10:34:25 AM	Fällig am		Status	In Progress	Prozess	Hausanschlussverfahren
Verantwortlicher	Köhler, Michael	Priorität	Medium				

▶ [Notizen \(0\)](#) | ▶ [Anhänge \(0\)](#)

Create standard electricity connection

Kundendaten

Kundennummer:	<input type="text"/>		
Vorname:	<input type="text" value="Max"/>	Nachname:	<input type="text" value="Mustermann"/>
Straße:	<input type="text" value="Postplatz"/>	Hausnummer:	<input type="text" value="1"/>
PLZ:	<input type="text" value="01010"/>	Ort:	<input type="text" value="Dresden"/>
Telefon:	<input type="text" value="0815"/>	E-mail:	<input type="text" value="max.mustermann@sap.com"/>

Netzanschluss

Straße:	<input type="text" value="Postplatz"/>	Hausnummer:	<input type="text" value="1"/>
PLZ:	<input type="text" value="01010"/>	Ort:	<input type="text" value="Dresden"/>
Gemarkung/Flur:	<input type="text"/>		

Hausanschluss

Angebots/Auftragsnr.:	<input type="text"/>
Auftrag erstellt	<input checked="" type="checkbox"/> Ja
Auftrag abgeschlossen	<input checked="" type="checkbox"/> Ja

Next steps

GISA plans to create template for entire Service Connection Mgmt process

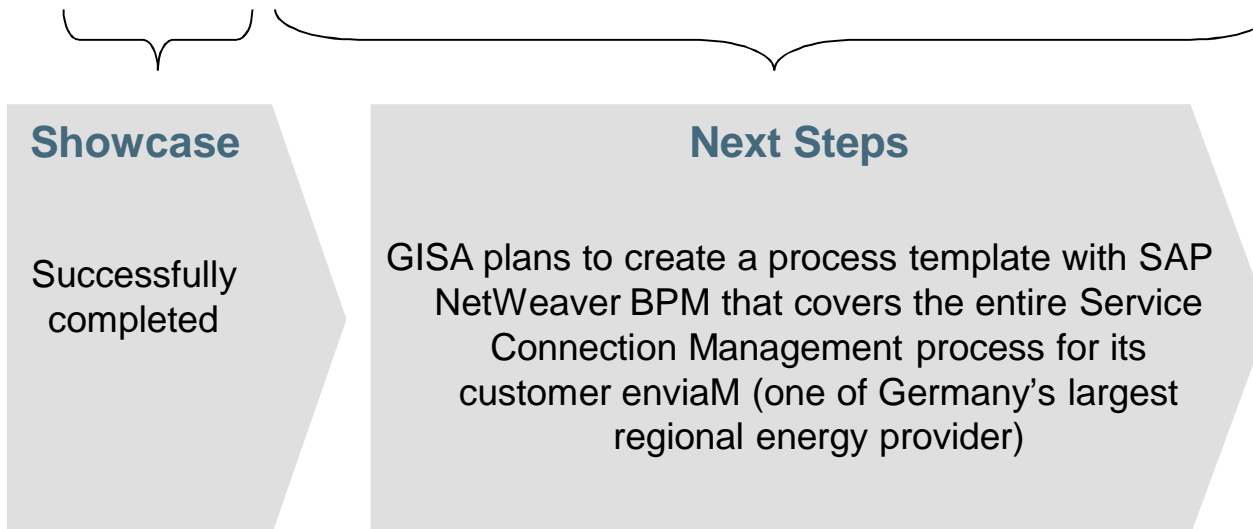
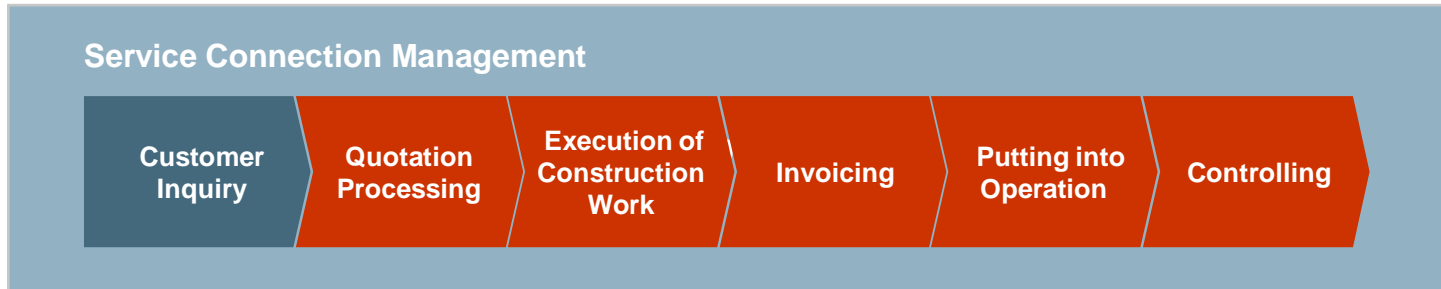

Agenda



1. Introducing BPM & Composite Applications
2. Business Process Modeling Notation as Lingua Franca for Processes
3. Loose Coupling – a Fundamental SOA Paradigm
4. Business Composition vs. Technical Composition
5. Write Operations out of Uis
6. SAP NetWeaver Composition Environment - Demo
7. Real world example for BPM
8. **Summary**

Summary – Building Process-Centric Applications with SAP NetWeaver



- Loose coupling is a fundamental SOA concept in large distributed heterogeneous landscapes! Its goal is to minimize dependencies between different systems
- SAP NetWeaver BPM allows business process experts and developers to create process-centric composite applications
- SOA facilitates an agile implementation and reuse of services, complementing BPM to achieve the goals of lower cost, better transparency, lower risk, and higher productivity
- SAP NetWeaver Composition Environment provides an integrated environment to deliver the value of SAP's enterprise services