

A COMPARATIVE STUDY OF THE SIP AND IAX VOIP PROTOCOLS

Taemoor Abbasi, Shekhar Prasad
Carleton University
Ottawa, Canada
taemoor, shekhar.prasad@gmail.com

Nabil Seddigh
Solana Networks
Ottawa, Canada
nseddigh@solananetworks.com

Ioannis Lambadaris
Dept. of Systems and Computer
Engineering, Carleton University
Ottawa, Canada
ioannis@sce.carleton.ca

Abstract

Recently, there has been a strong focus on the development of scalable Voice over IP (VoIP) protocols, which are suitable for wide scale deployment. SIP (Session Initiation Protocol) is one such protocol which has been the subject of extensive research over the past few years. More recently, IAX (InterAsterisk Exchange Protocol) has emerged as a new VoIP protocol which is steadily gaining credence among the open source community. Among the benefits claimed by the proponents of IAX are its simplicity, NAT-friendliness, efficiency and robustness. This paper makes three key contributions to VoIP research. Firstly, we undertake a comparative evaluation and analysis of the SIP and IAX protocols. Secondly, we report on the viability of utilizing the Asterisk PBX as a foundation for conducting research performance studies for VoIP. Finally, we report on live experimental studies of SIP and IAX voice traffic in the Ottawa Metropolitan area. We experimentally studied the performance of voice calls initiated using SIP and IAX for a variety of delay and loss characteristics. In addition, we examined the performance of both protocols in the presence of packet reordering. Our preliminary observations demonstrate that the IAX protocol compares favourably in relation to SIP. More detailed studies are required to evaluate the performance of IAX-based voice traffic in large-scale deployment.

Keywords: VoIP; SIP; IAX; Asterisk.

1. Introduction

In recent years, there have been strong efforts to develop Voice over IP (VoIP) protocols that can operate over the current Internet infrastructure and perform gracefully with large scale global deployment. VoIP communication typically consists of two types of protocols: (i) Signaling protocols, which are used to setup a voice conversation and manage voice sessions (ii) Media transfer protocols are used for exchange of voice data traffic once the session is established.

Delivering real-time data such as VoIP robustly over the current Internet is a challenge due to the best-effort nature of this global infrastructure. To obtain suitable quality voice conversation, there is a need to minimize jitter, reordering and loss of VoIP packets. Efficient protocols that make best use of available resources are required. Two popular standardized

VoIP protocols are H.323 and Session Initiation Protocol (SIP). SIP's lightweight call setup mechanisms have proven particularly attractive and are a key reason why this protocol has been the subject of extensive research in recent years. The SIP signaling protocol was standardized in the IETF (Internet Engineering Task Force) RFC 2543 and further extended in RFC 3261. SIP is typically used in conjunction with the Real Time Transport Protocol (RTP) for real time media transfer. It is a text based protocol with a structure very close to HTTP and SMTP [14].

Recently, IAX (InterAsterisk Exchange Protocol) has emerged as a third VoIP protocol which is gaining more widespread attention, particularly among the open source community. Like SIP, IAX is a peer-to-peer VoIP protocol with capability for signaling as well as media transfer [10]. At present, there do not appear to be any efforts at the IETF to standardize the IAX protocol although we speculate that this is inevitable. IAX appears to be structurally very similar to SIP with a claim of being more bandwidth efficient and providing better performance. The authors of IAX adopted design goals with the objective of improving performance over existing VoIP protocols. These design goals included [10]: (i) Minimize bandwidth usage for signaling and media transfer, with a particular emphasis on voice (ii) Ensure NAT transparency (iii) Ability to exchange dial plans (iv) Efficient implementation of intercom and paging features.

The objective of this paper is to experimentally study and analyze the IAX protocol operation and performance with the intention of comparing it against the SIP-based VoIP conversations. The experimental study of live VoIP traffic was carried out utilizing the Asterisk open-source PBX. We believe that this is one of the first published research studies that evaluates the IAX protocol. Section 2 compares SIP and IAX operation followed by related studies in section 3. In section 4, we clarify the methodology utilized for assessing voice quality in the experimental study. Section 5 provides an overview of the experimental setup used for our research. The actual experimental detail is captured in section 6. In section 7, we briefly discuss the use of Asterisk for research purposes. Section 8 outlines our conclusions and points to future work.

2. Comparison of SIP and IAX

The authors of IAX point to ten major differences between the 2 peer-to-peer VoIP protocols. In the following sub-

sections, we analyze four of these differences which we believe are the most crucial. Our experiments in this work will focus on the second key difference listed below. We leave experimental study of the remaining differences to future research.

2.1. Signaling and Structure

The SIP and IAX signaling techniques appear to be relatively similar in nature. Messages for both protocols can be grouped into 2 categories namely “requests” and “responses”. SIP has a 4 byte basic header. Apart from the basic header fields, RFC 2543 lists 44 different header fields for transmission of various information. IAX signaling utilizes full frames which have a header size of 12 bytes and can customize a wide variety of control signals. For basic operational scenarios including call setup and teardown, SIP and IAX closely resemble each other. For signaling, both protocols have a built-in reliable delivery mechanism [10] [11].

2.2. Media Transfer

SIP and IAX have very different approaches for supporting the exchange of voice packets. Once the session is established, SIP hands over the media transfer responsibility to some other protocol. In case of real-time voice or video, the commonly used media transfer protocol is RTP, which has a header size of 12 bytes. IAX on the other hand does not rely on any other standard media transfer protocol but uses a lighter version of its full frames called the IAX mini-frames. These mini-frames only have a 4-byte header which is composed of the source call number and the lower two octets of the timestamp. Figure 1 shows the architecture of IAX mini-frames. Both RTP and IAX mini-frames are transmitted using UDP.

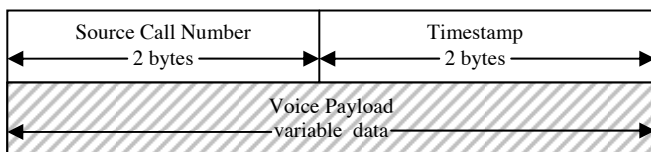

Figure 1 IAX mini-frame packet [10]

2.3. Signaling Efficiency

In comparison to H.323, both SIP and IAX can be classified as lightweight protocols. From analysis of their signaling messages, it does not appear as though there should be significant difference in terms of scalability and efficiency of their call setup, management and teardown, although this needs to be validated via future experiments.

2.4. Network Address Translation (NAT)

NAT is a technique used by routers and firewalls to allow multiple devices on a LAN to share a single static IP address. A frequent problem with SIP operation is traversal through

NAT-enabled routers. This problem is not only SIP specific but typical in the case of all protocols that use separate ports for control and media flow. In the case of SIP, to enhance privacy, the port for media transfer is dynamically chosen every time a session is established. When a NAT enabled router tries to connect the client with a private IP address to an external server, the server sends the media flow on a port other than the one that initialized the connection. In such a situation, the NAT router is unable to relate the newly opened port (dynamically picked by the server) to the client that initiated the request. There are a number of workarounds to the NAT traversal problem, but none of them appears to be universally acceptable. A permanent solution to the SIP NAT traversal issue is under discussion, and is documented as Internet Draft [12]. IAX appears to avoid NAT issues by utilizing the same port for control and media flow.

3. Related Work

There have been a number of VoIP related studies in recent years. In [1], Markopolo et al conducted a live study of VoIP traffic over the Internet. Their findings showed that a surprisingly varying quality of voice conversation was achieved. To a large extent this is attributable to diverse loss, delay and jitter characteristics on the best-effort Internet.

Many of the VoIP studies utilize models of Mean Opinion Score (MOS) as the method to measure call quality. Ding et al [2] have investigated the effects of packet loss on speech quality in VoIP applications. MOS was used to measure subjective voice quality. The quality parameters were measured through simulation. Furuya et al [3] studied the relationship between IP network performances and voice quality for VoIP service through extensive experiments on a test bed network. The experiments encompassed variations in average delay (jitter), standard deviation of jitters, standard deviation of packet inter-arrival times, and packet loss ratio. The works of Roychoudhuri et al [4] outline the factors that can influence the quality of audio in IP telephony. These factors include type of encoder, distance, delay variation, rate and distribution of packet loss, and type of error concealment. Takahashi et al [5] [6] proposed a systematic model to gauge the quality of service (QoS) of VoIP systems. This approach is different from the MOS model, and investigates another model also known as the E-model. The E-model is objective in nature, but the suggested improvements will make it more subjective and improve quality estimation accuracy.

In [13], Zhang undertook an in-depth analysis of the SIP protocol and compared it with the existing H.323 protocol. Zeadally and Siddiqui [14] examined the usefulness of the SIP protocol for VoIP communication over a wide range of parameters. The IAX protocol has been described by Spencer and Miller in [10]. However, we have not found any studies of IAX protocol performance.

4. Voice Quality Assessment Methodology

This research study evaluates the performance of the SIP and IAX protocols under varying network conditions. The sole criterion for comparing performance is voice quality. Hence, it is important to adopt a reproducible methodology to make the comparison results reliable. [6] describes a number of different methods that have been standardized to assess voice quality. The methods can be grouped into 2 categories: i) objective voice quality assessment; ii) subjective voice quality assessment. Objective voice quality assessment uses a number of different parameters that are indicative of the network and terminal conditions. Based on these parameters a score is produced. The E-model standardized by the ITU-T is one of the popularly used objective assessment methods.

On the other hand, subjective voice quality methods actually take into account the listener's opinion with regard to voice quality. For a reliable study, a reasonable number of data points are required. Although this effort is extremely time consuming, we selected it because in our opinion the user is the ultimate judge of voice quality. Published methods for subjective analysis include opinion rating and equivalent-q method [6].

4.1. Opinion Rating

Opinion rating is the most widely used subjective assessment technique used. It is standardized by the ITU-T in Recommendation P.800 [9]. For our research studies, the performance of the system was rated directly (ACR, absolute category rating). Listening subjects were given a scale between 1 to 5, where 1 = bad, 2 = poor, 3 = fair, 4 = good, 5 = excellent. The experiments were conducted in multiple languages including English, Hindi and Urdu. For this reason, the scale was translated appropriately depending on the language. Based on scoring from a number of users, an average was taken for each scenario (based on varying conditions of delay, packet loss and packet reordering). This average formulates the metric used to display our experimental results. This average is the mean opinion score (MOS).

To judge subjective voice quality, both conversational and listening quality should be taken into account. Conversational quality is particularly important, especially when judging the metric for delay. To increase the effectiveness of our study, different forms of conversation were utilized. This was based on the tasks described by Kitawaki et al in [9]. Our experimental study involved 11 test subjects that listened to similar emulated scenarios and an MOS value was calculated as an average of their score. A larger number of test subjects would assist in gaining further confidence in the MOS results. However, this is left for future exercise. We observed that a significant number of VoIP research papers fail to acknowledge the number of test subjects used for their experiments.

5. Experimental Setup

Figure 2 displays the experimental setup that was used to conduct the studies. Asterisk is an **open source software based PBX** which supports SIP, IAX, and H.323 VoIP protocols along with a number of voice codecs. Due to its versatility, Asterisk was deployed to connect the different clients. The IP based phones and devices were connected to the PBX via the Ethernet port. Connection with the traditional PSTN line was facilitated via a FXO port on the PBX, which performed analog to digital conversion between the incoming and outgoing voice streams.

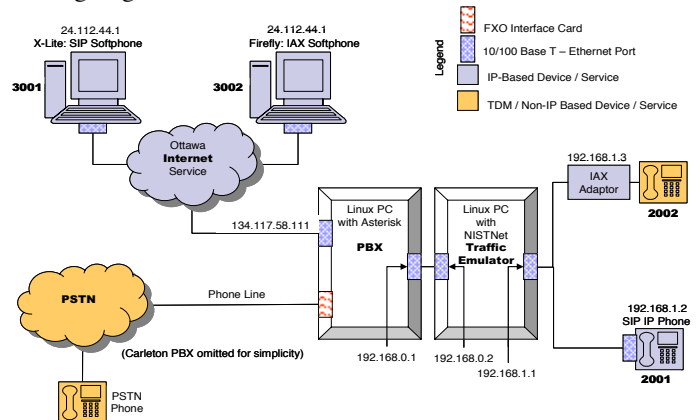

Figure 2: Experimental Setup

In order to maintain consistency, G.711 ULAW was the only voice codec used in the tests with both protocols. Basic features such as caller-ID, call-waiting, voicemail, and voice-email were also implemented through Asterisk's configuration scripts. Operation and feature performance were validated prior to experimentation.

Extension 2001 in the testbed was a SIP-based Grandstream Budgetone 102 phone. Extension 2002 consisted of a Digium IAXy IP adaptor which connected a legacy POTS phone to the Ethernet port of the PBX. This adapter utilized IAX for its communication.

A traffic emulator, NISTNet, was placed between the two phones mentioned above (ext 2001 & ext 2002) and the PBX. This was done in order to control the network conditions, conduct repeatable experiments and observe relative call quality. NISTNet supports emulation of a wide range of network characteristics including loss, delay, reordering, and duplication of packets.

Extensions 3001 and 3002 were softphone clients installed on PCs in other locations on the Internet. Ext 3001 was an X-Lite IP softphone, which communicates over SIP, while ext 3002 was an IAX based client supplied by Firefly IP softphone.

6. Experiments

Our experiments focused on comparing the performance of SIP and IAX in the presence of three types of network impairment: *packet delay*; *packet loss*; and *packet re-ordering*.

A sample of 11 subjects was used in order to obtain the average MOS for each set of tests. For controlled testing, studies with the SIP protocol performance were undertaken by establishing a voice call between extension 2001 and a PSTN-based phone via the Asterisk PBX, as shown in Figure 2. Similarly, studies with the IAX protocol were undertaken by establishing a voice call between extension 2002 and a PSTN-based phone via the Asterisk PBX. Both types of calls were terminated on PSTN phones in order to ensure reproducible network conditions. In our setup, NISTNet introduced the desired network impairments in a controlled fashion. A pre-scripted 30 second conversation was used to gauge the voice quality for each point on the X-axis.

6.1. Performance with Packet Loss

Research data already collected indicates that average packet loss ranges from an average of 0% to 7% worldwide [7]. In particular, it is between 0% to 3% within North America and Europe. To compare the protocols, performance was examined with loss rate ranging from 0% to 10%, with increments of 0.25%. We note that there are portions of the Internet that have loss rates higher than 10%. At such loss rates the voice quality is appreciably diminished.

The experimental results are displayed in Figure 3. The results indicate that IAX maintains a higher call quality as the loss rate increases. Over the range of measurements taken, the root-squared performance of IAX displays a performance improvement by 0.513 MOS points and a relative performance improvement of 24.70% over SIP.

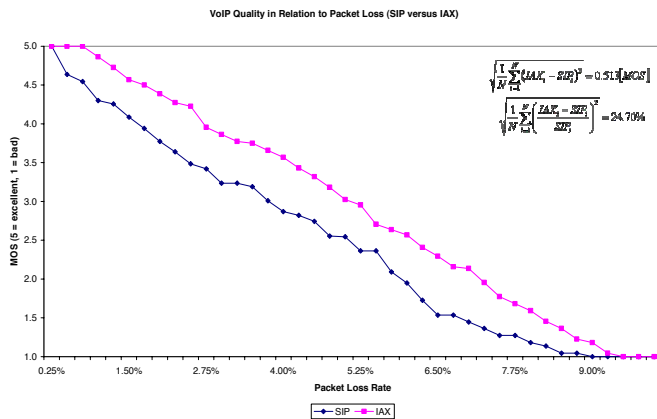

Figure 3: Packet Loss – SIP versus IAX

6.2. Performance with Packet Delay

Average packet delay ranges between 80 to 400 ms worldwide [7]. In North America and Europe, the average is between 80 to 200 ms. In order to study quality effects due to packet delay, both protocols were compared with fixed packet delay ranging from 0 to 2000 ms with increments of 25 ms. This assumption accommodates satellite links as well. We acknowledge that delay between 2 points is not constant and

recognize that future studies should investigate the impact of jitter on the 2 protocols.

As Figure 4 indicates, both protocols perform comparably in the presence of fixed delay though IAX appeared to perform slightly better. The average root-squared distance calculated as before between the two protocols is 0.155 MOS points. The relative performance improvement of IAX is 7.16% over SIP.

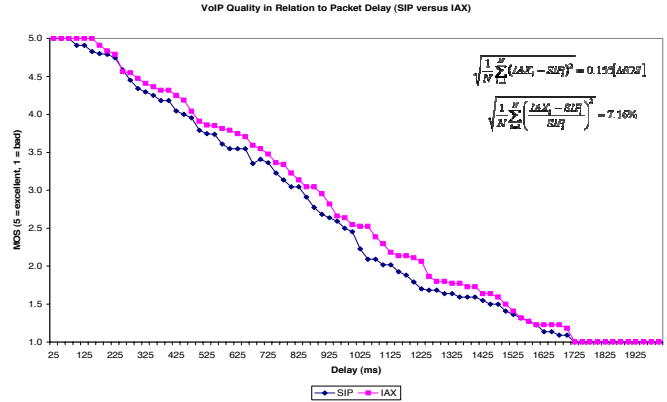

Figure 4: Packet Delay – SIP versus IAX

6.3. Performance with Packet Re-ordering

Although packet re-ordering varies from 0% to 100% in parts of the world, within the North America and Europe, it averages between 1% and 18% [8]. NISTNet reorders packets by allowing the user to specify an average and standard deviation for packet delay. The resultant distribution will cause a certain percentage of packets to arrive at the destination out-of-order.

In order to understand the degree of packet re-ordering caused by a particular combination of average and standard deviation delay, we exchanged stream of UDP packets between 2 computers across NISTNET. A program based on the algorithm in [15] examined sequence numbers of packets transmitted between two hosts to identify the amount of re-ordering. We display the results in Table 1 because they assist in understanding the x-axis for Figure 5.

Table 1: Packet Reordering based on average delay of 100 ms with varying standard deviation (sigma)

Standard Deviation of packet delay (ms)	nth order reordering (%)					
	1	2	3	4	5	6
0	0	0	0	0	0	0
5	2.52	0	0	0	0	0
10	4.19	0.16	0	0	0	0
15	5.93	0.33	0	0	0	0
20	8.44	1.31	0.16	0	0	0
25	10.18	1.64	0.52	0	0	0
30	13.68	2.29	0.82	0.23	0	0
40	17.55	3.13	1.89	0.38	0.09	0
50	17.66	5.51	1.96	0.75	0.65	0
60	19.99	6.88	1.84	1.55	0.48	0.39

Figure 5 displays the outcome of testing based on standard deviation values. The average delay was set to 100 ms and standard deviation was varied from 0 ms to 30 ms with intervals of 2.5 ms. The results show that IAX has improved performance over SIP. The root-squared average performance

improvement of IAX over SIP is an MOS of 0.137. The relative improvement of IAX over SIP is approximately 7.27%.

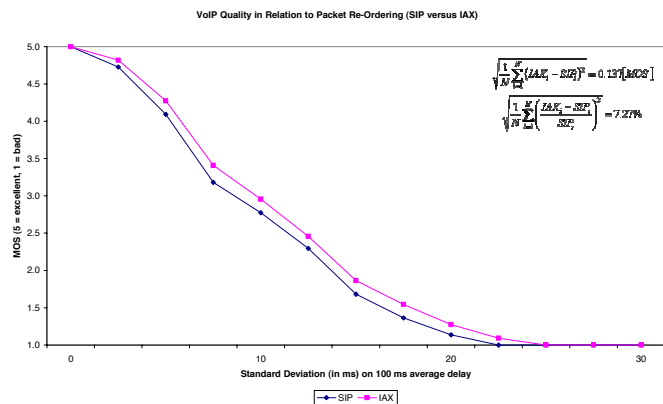

Figure 5: Packet Reordering – SIP versus IAX

6.4. Live Internet Performance Study

Preliminary testing over the Internet resulted in slightly better performance for IAX, although these results are not conclusive. Using the same test subjects over a varying time period, SIP obtained a MOS of 2.3, whereas IAX obtained a MOS of 2.9. Both hosts were based in the Ottawa area, where extension 3001 represented a SIP-based softphone and extension 3002 represented an IAX-based softphone from Figure 2.

7. Viability of Asterisk for research purposes

The Asterisk PBX is based on open-source code. Our use of Asterisk revealed some challenges in terms of ease of setup. For example, configuration files had to be updated when a new hardware was added to the network.

Implementing and modifying features requires a thorough understanding of Asterisk’s configuration scripts and its dialplan structure. Since Asterisk is open-source, dedicated technical support is not available. Strong familiarity with the Linux operating system and programming languages is essential for setting up Asterisk and implementing customized features. Asterisk could strongly benefit from new features to assist with configuration and customization. Asterisk also supports most common VoIP protocols including SIP, H.323, and IAX. Along with this, support for most codecs is available. An FXO interface card is required to connect with the traditional PSTN network.

Based on our experience, we feel that Asterisk provides a viable means to serve as a test platform for research in the area of VoIP protocols.

8. Conclusion

This paper has undertaken one of the first experimental studies comparing the performance of the IAX and SIP protocols. Our preliminary research demonstrated that IAX appears to perform better in comparison with the established

SIP protocol. Further, for the controlled tests over the specific loss rates examined, IAX achieved a 25% improvement in voice quality via the MOS score. This has been verified through controlled testing over a limited set of parameters as well as testing over the live Internet with hosts residing in Ottawa. The difference in performance between SIP and IAX requires further validation utilizing a much larger set of test subjects. Initial investigation revealed that this improvement could potentially be attributed to the fact that the headers of IAX mini-frames are also much smaller than that of RTP, which allows for better utilization of bandwidth by IAX. In order to validate our findings, further research of the IAX and SIP protocols and their performance under various conditions is recommended. In addition, the test setup has proven Asterisk to be a viable PBX for further research studies.

Acknowledgements

We would like to thank Biswajit Nandy, Rupinder Makkar, and Vikas Paliwal for their support and guidance throughout the study. We also appreciate the contribution of our test subjects.

References

- [1] A.P. Markopoulou, F.A. Tobagi, M.J. Karam, “Assessment of VoIP Quality over Internet Backbones,” *IEEE/ACM Transactions on Networking*, Volume: 11, Issue: 5, Oct. 2003
- [2] L. Ding, R.A. Goubran, “Assessment of Effects of Packet Loss on Speech Quality in VoIP,” *The 2nd IEEE International Workshop on Haptic, Audio and Visual Environments and Their Applications*, 20-21 Sept. 2003
- [3] H. Furuya et. al, “Experimental Investigation of the Relationship between IP Network Performances and Speech Quality of VoIP,” *10th International Conference on Telecommunications*, 23 Feb.-1 March 2003 Pages:543 - 552 vol.1
- [4] E. Al-Shaer et al, “On Studying the Impact of the Internet Delays on Audio Transmission,” *IEEE Workshop on IP Operations and Management*, 2002 Pages:208 - 213
- [5] A. Takahashi, “Opinion Model for Estimating Conversational Quality of VoIP,” *IEEE International Conference on Acoustics, Speech, and Signal Processing*, Volume: 3, 17-21 May 2004 Pages:iii - 1072-5 vol.3
- [6] A. Takahashi, H. Yoshino, “Perceptual QoS Assessment Technologies for VoIP,” *IEEE Communications Magazine*, Volume: 42, Issue:7, July 2004 Pages:28 - 34
- [7] “Network Overview Internet Traffic Report,” February 2005, <http://www.internettrafficreport.com/main.htm>
- [8] “Packet Reordering,” February 2005, <http://www-iepm.slac.stanford.edu/monitoring/reorder/>
- [9] N. Kitawaki, “Pure delay effects on speech quality in telecommunications,” *IEEE Journal on Selected Areas in Communications*, Volume: 9, Issue: 4, May 1991 Pages:586 - 593
- [10] M. Spencer, F. Miller, “IAX Protocol Description,” February 2005, <http://www.cornfed.com/iax.pdf>
- [11] “IEC: IP/IN Integration,” February 2005, http://www.iec.org/online/tutorials/ip_in/topic05.html
- [12] “An Extension to the Session Initiation Protocol (SIP) for Symmetric Response Routing,” IETF Internet Draft, version 1, February 2005
- [13] Y. Zhang, “SIP-based VoIP network and its interworking with the PSTN,” *Electronics & Communication Engineering Journal*, December 2002, Volume 16, Issue 6, pg 273-282
- [14] S. Zeadally, F. Siddiqui, “Design and Implementation of a SIP-based VoIP Architecture,” *AINA 2004*, Vol 2, page 187-190
- [15] A. Morton et al, “Packet Reordering Metric for IPPM,” February 2005, <http://www.ietf.org/internet-drafts/draft-ietf-ippm-reordering-09.txt>